

K'NEX Shake Table Instructions

By:
Alex Baker, MSCE

Project Advisor:
Daniel M. Dowden, PhD, SE

Michigan Technological
University

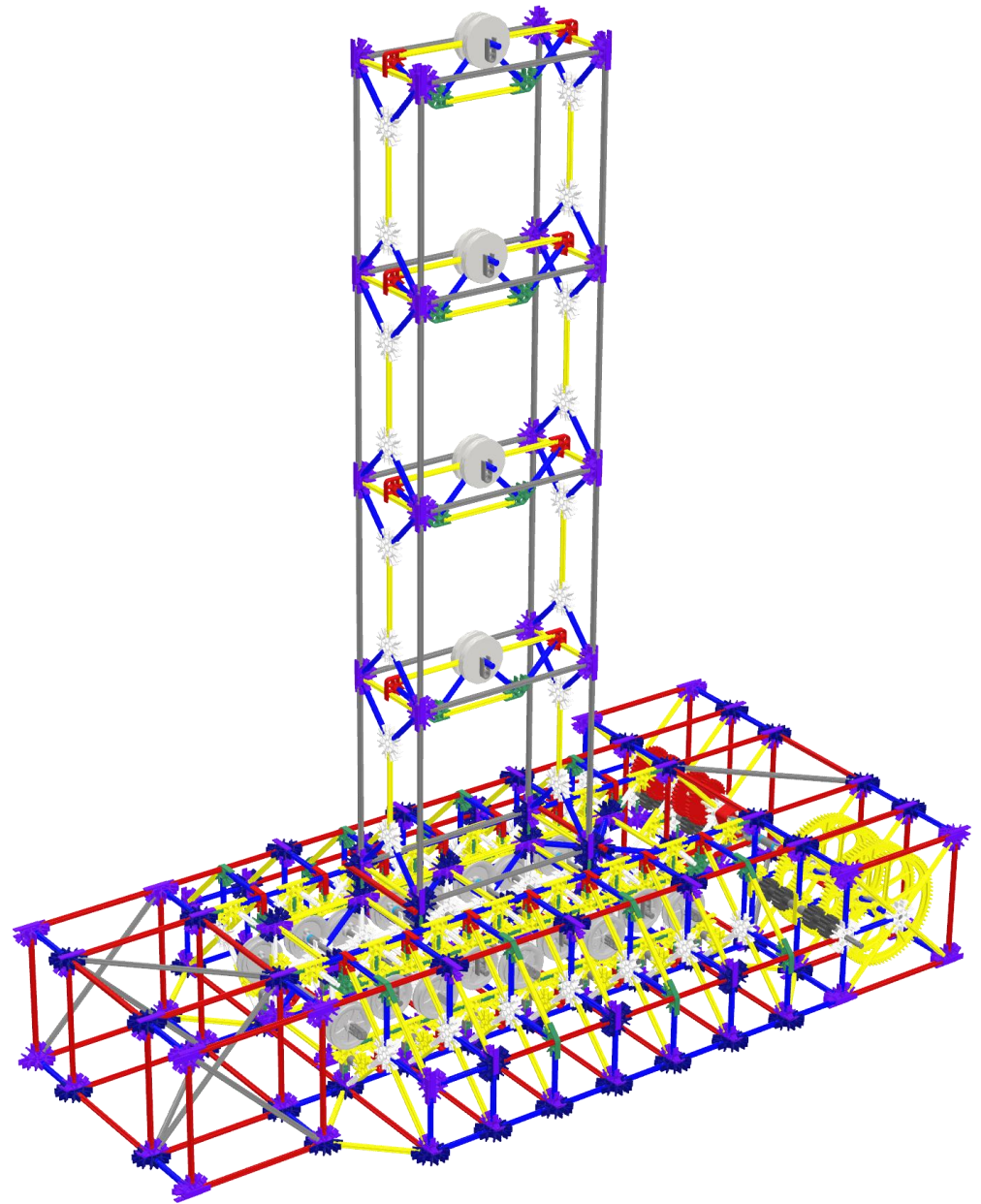

About

This shake table was developed to make structural dynamics a more approachable and affordable topic for all ages.

Thanks to Dr. Daniel M. Dowden (Dept. of Civil, Environmental, and Geospatial Engineering), who supported the development of the K'NEX shake table as part of a summer STEM internship program at Michigan Technological University.

Copyright © 2022 Alex Baker (ambaker1@mtu.edu)

K'NEX is a registered trademark of K'NEX Limited Partnership Group.

This work is licensed under a [Creative Commons Attribution-NonCommercial 4.0 International License](https://creativecommons.org/licenses/by-nc/4.0/).



Overview:

The K'NEX shake table instructions is split into 5 parts:

- A. Track
- B. End Piece
- C. Cart
- D. Gear box
- E. Tower

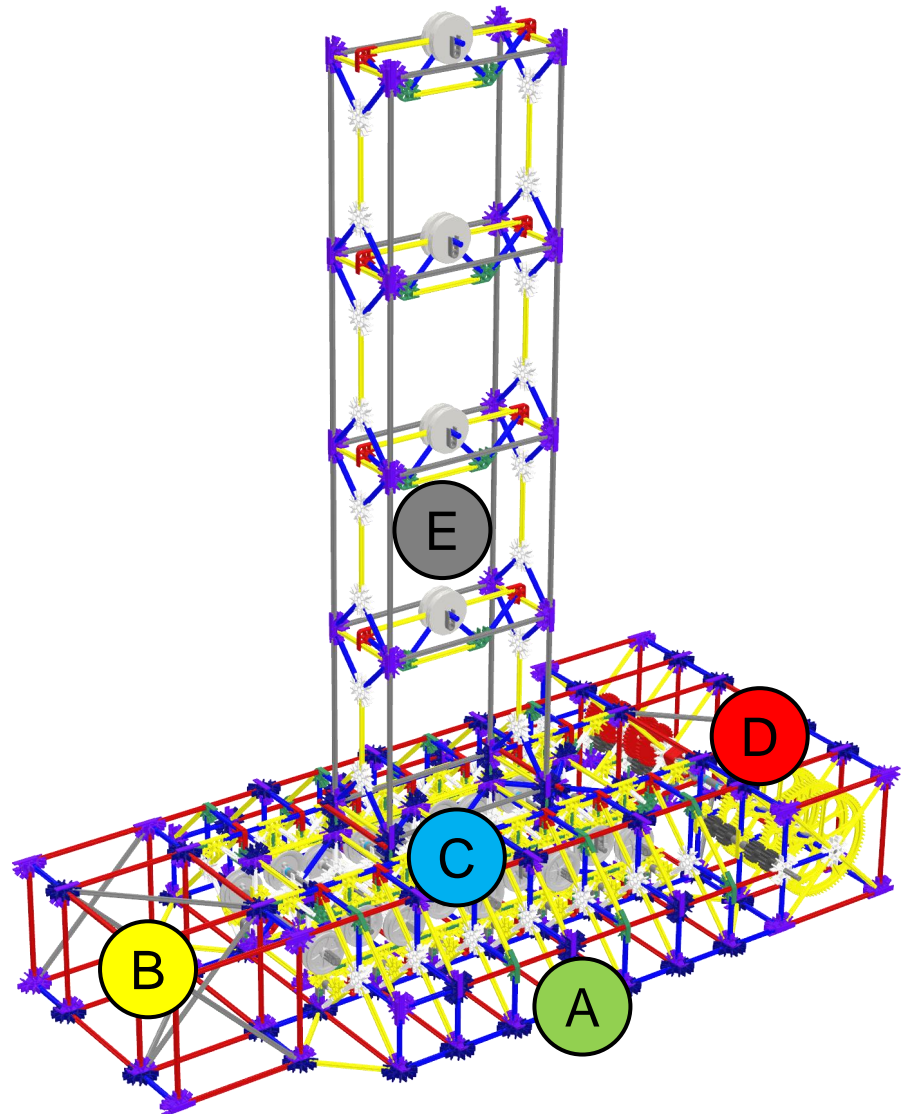

Parts list:

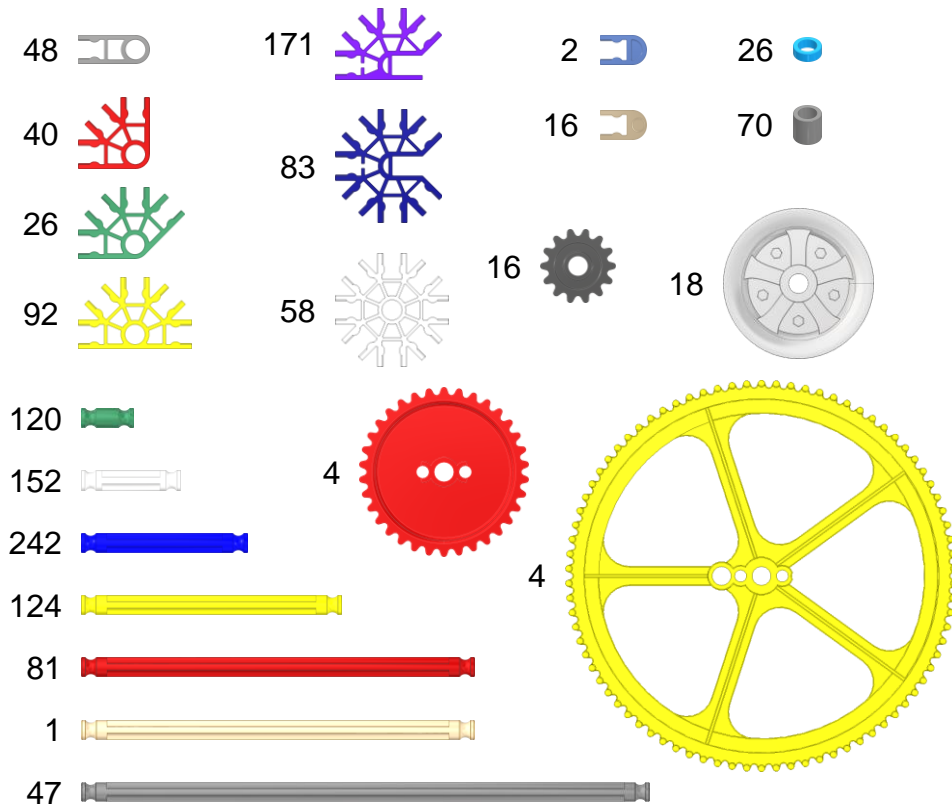

Non-K'NEX parts

1/4" inner diameter
large washers

Power drill

Part count is for shake table with basic 4-story building.

Part A: Track

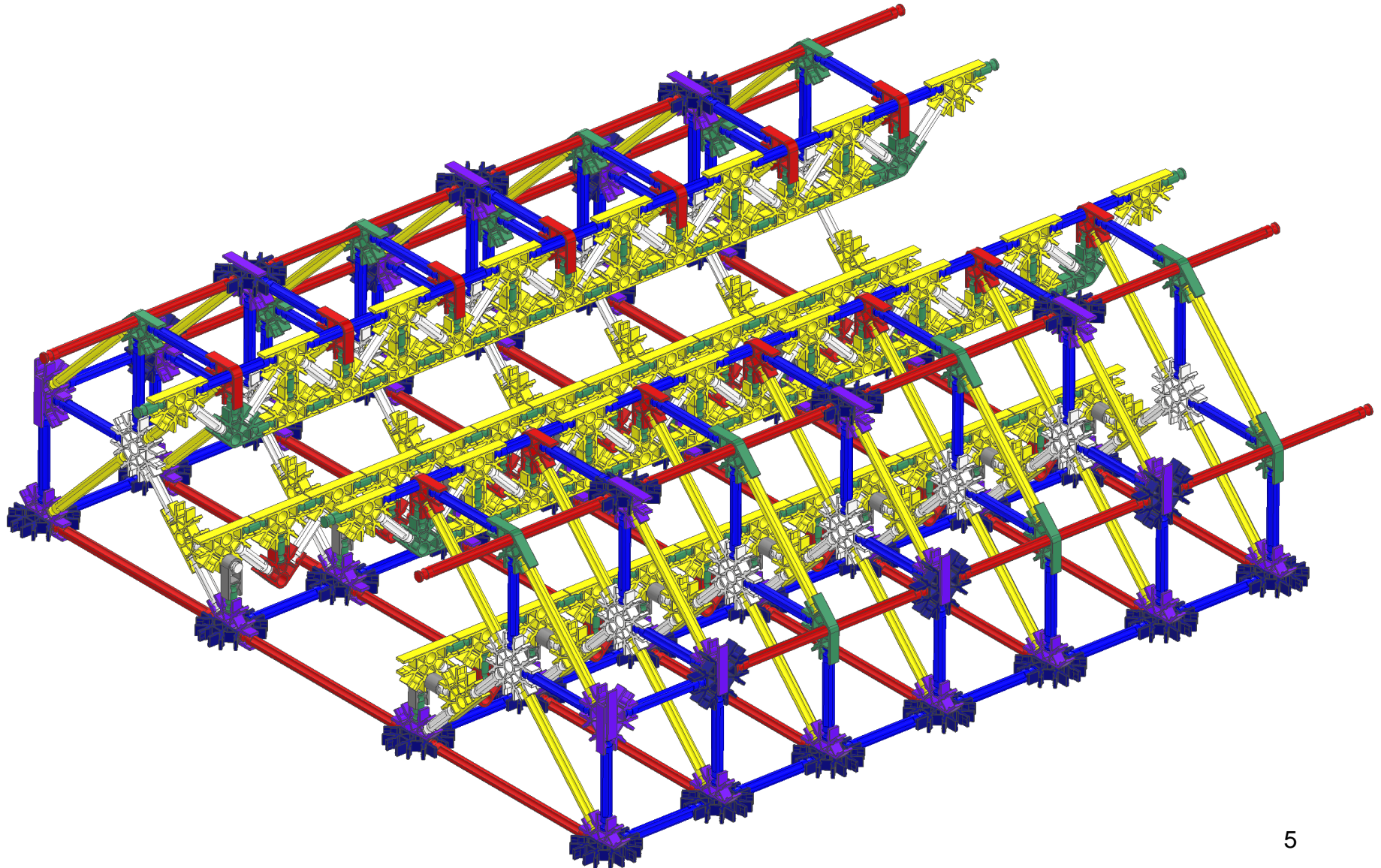

A1

Build track support sections

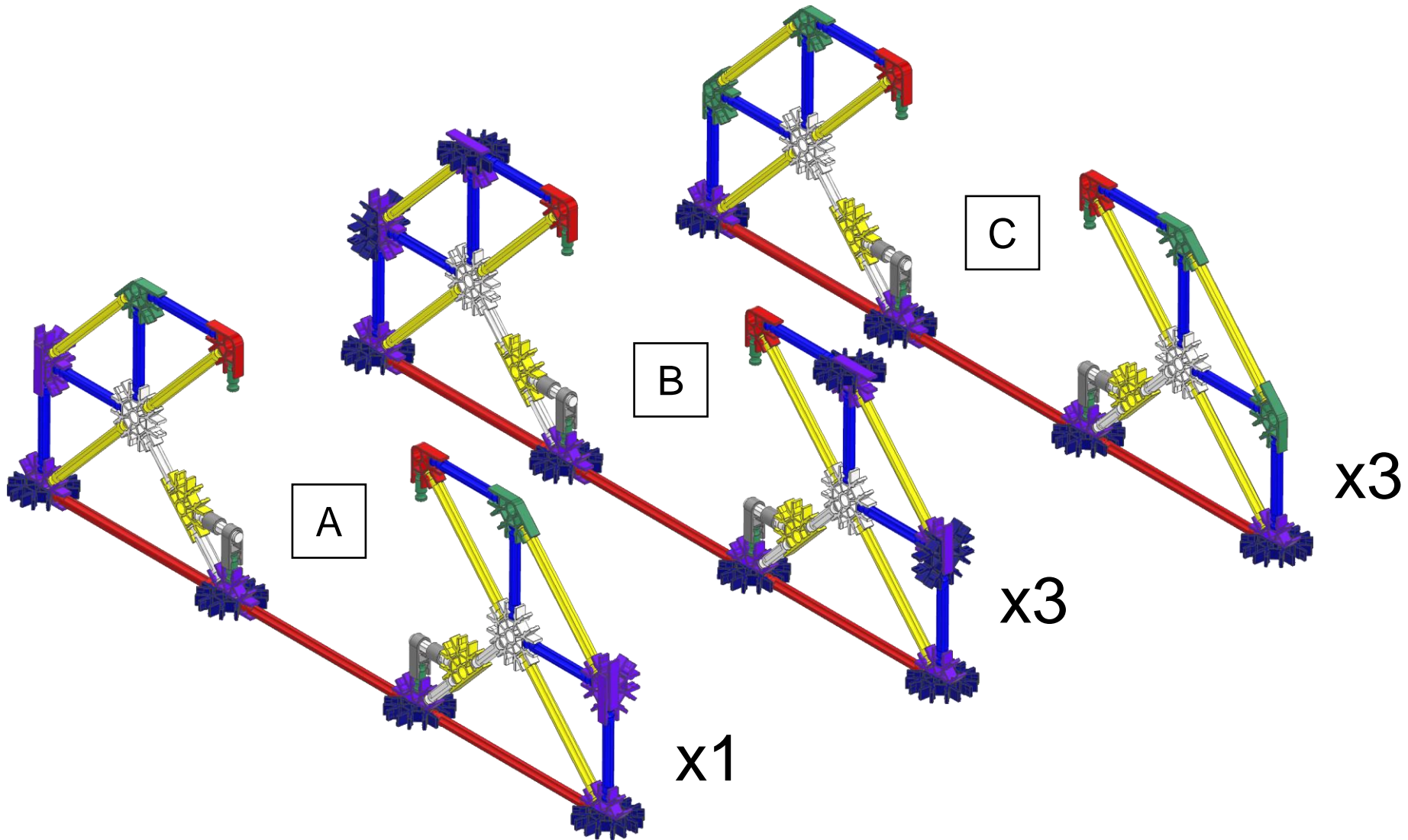

A2

Connect track support sections together

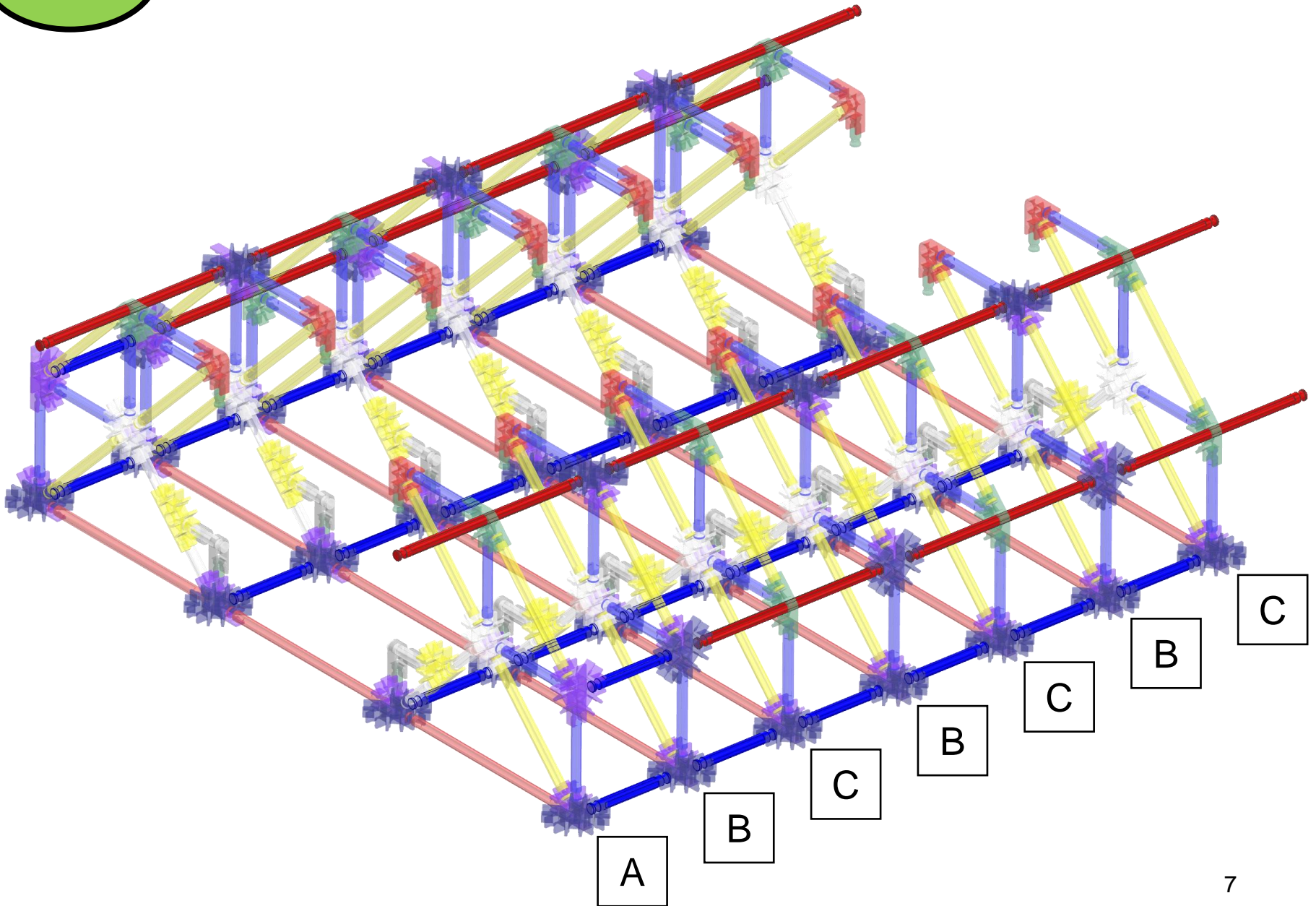

A3

Build and install bottom track

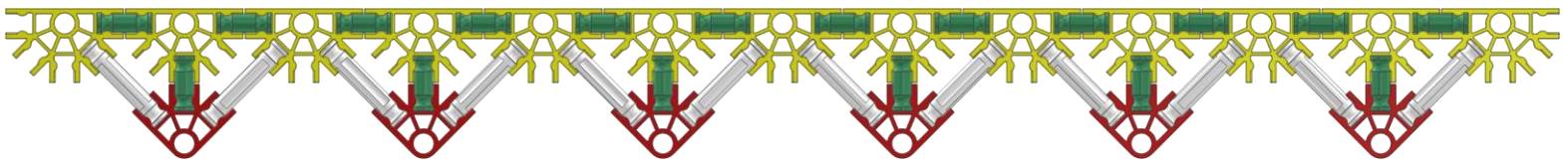
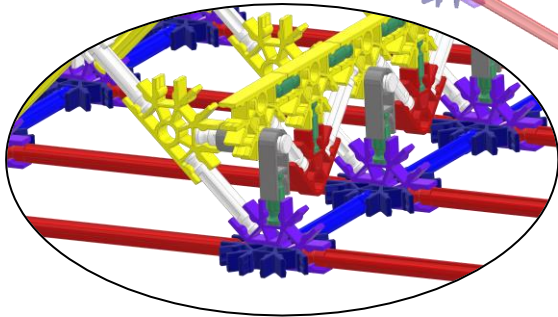
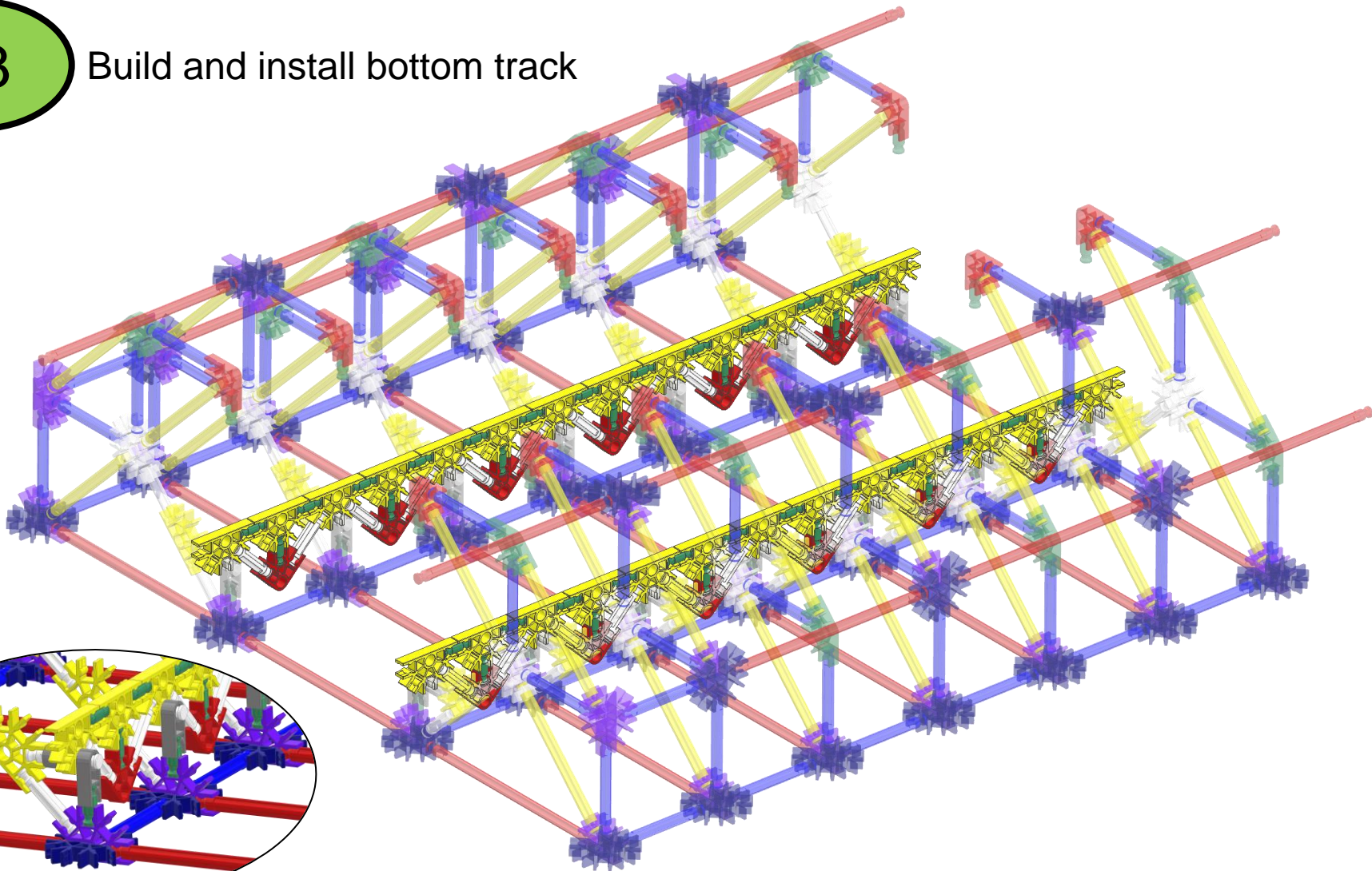

x2

A4

Build and install top track

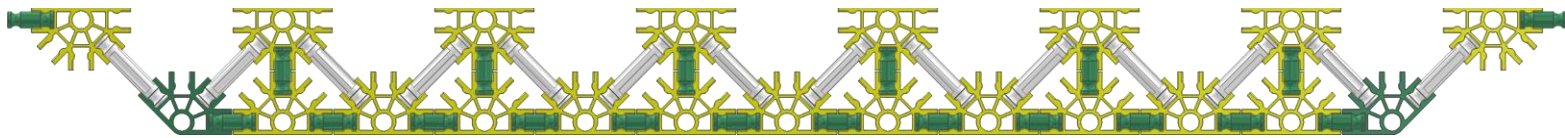
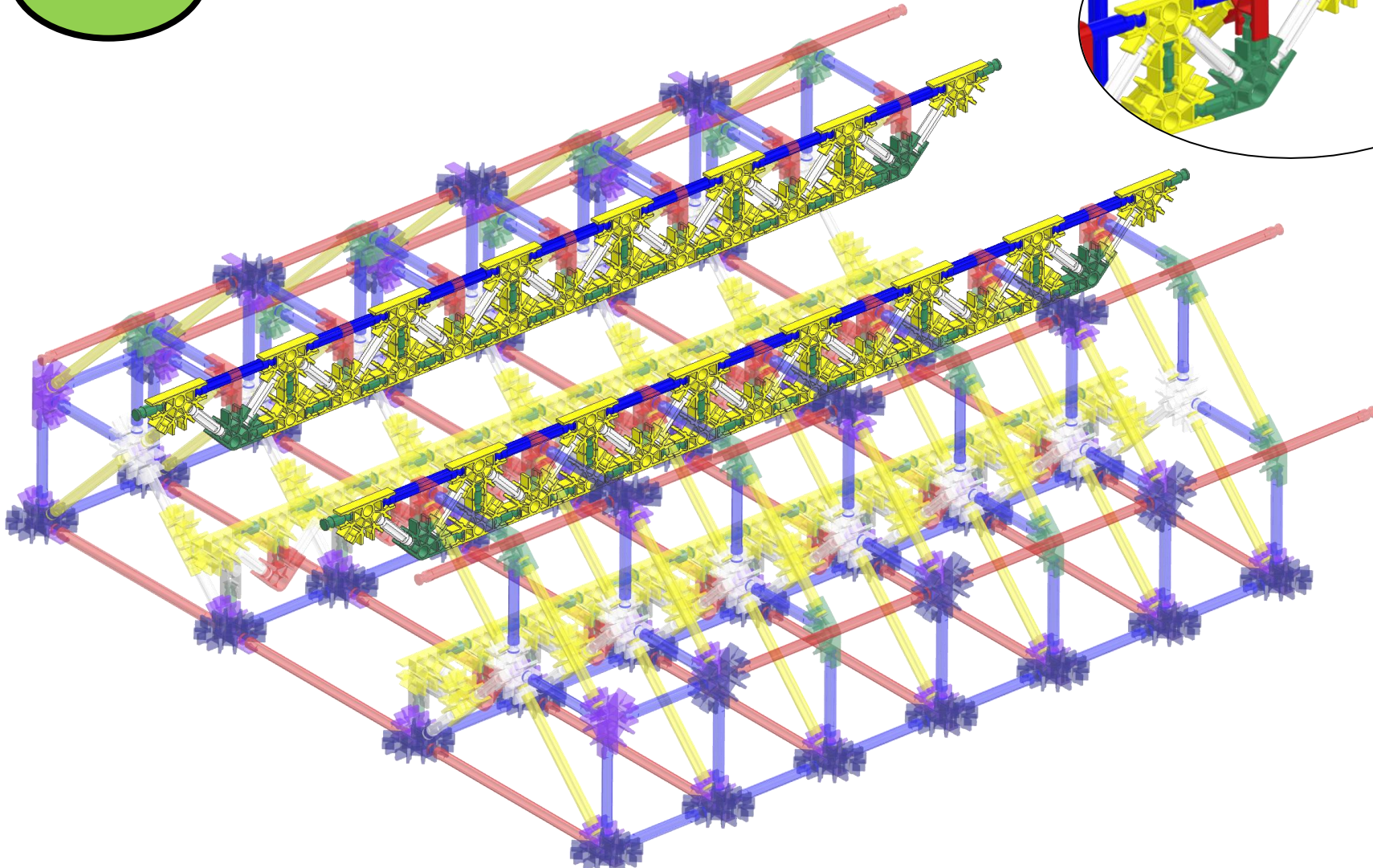
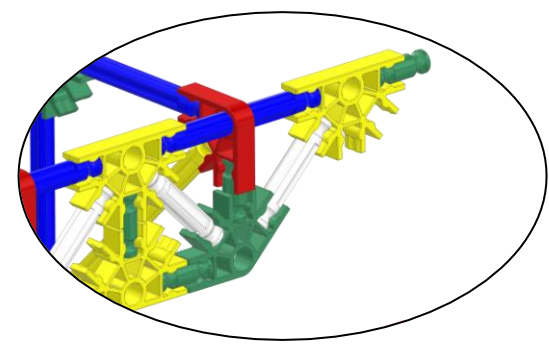

x2
9

Part B: End Piece

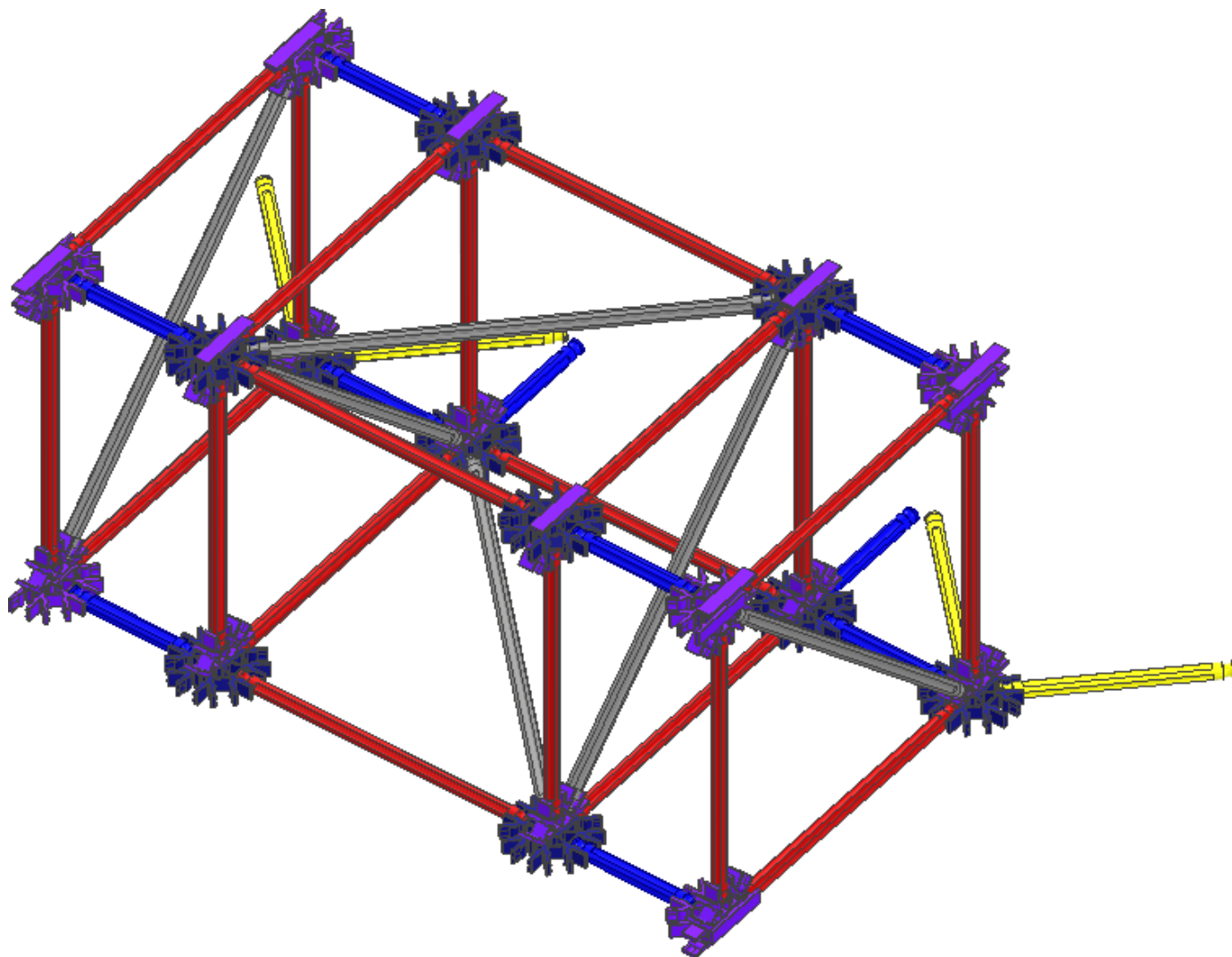

B1

Build base

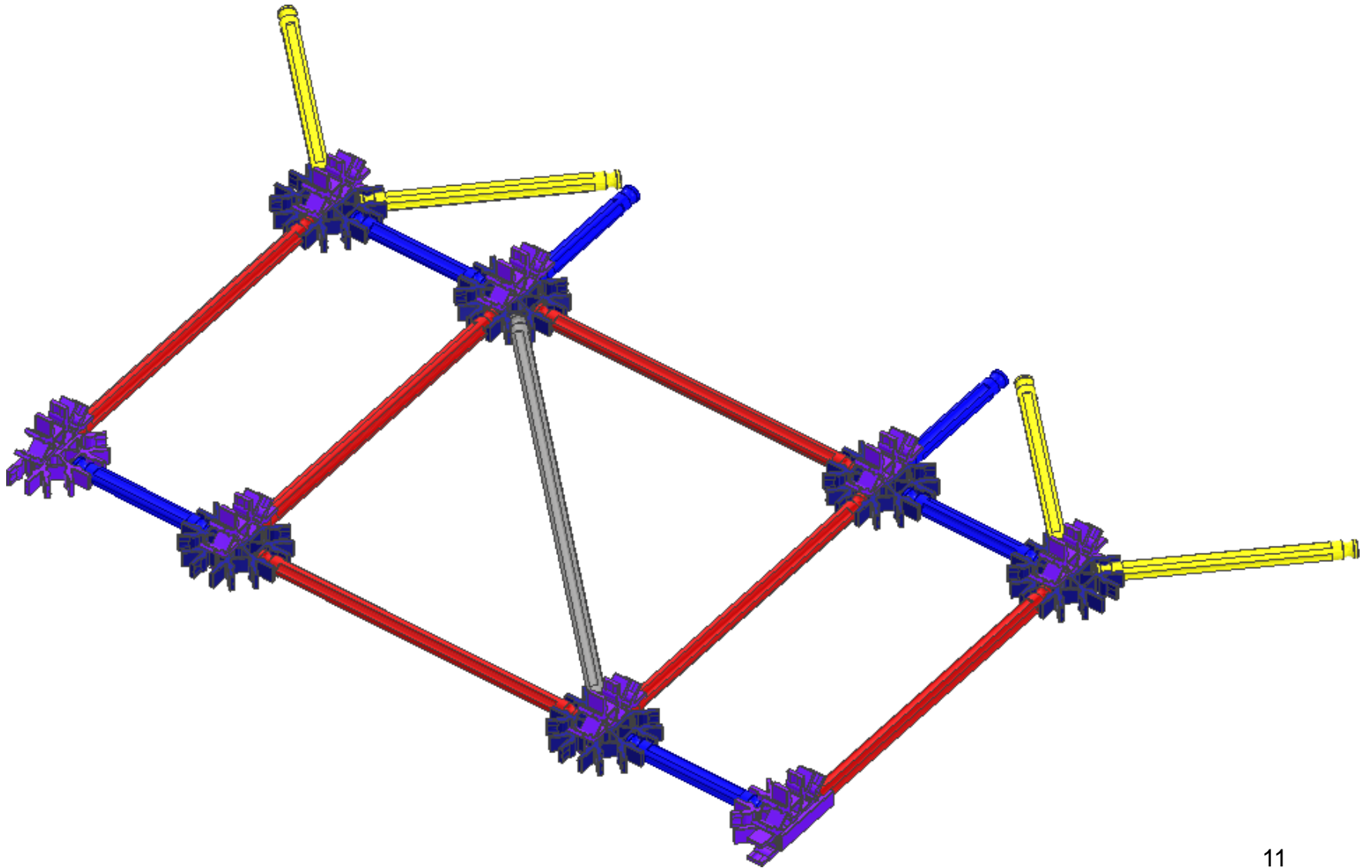

B2

Attach vertical rods

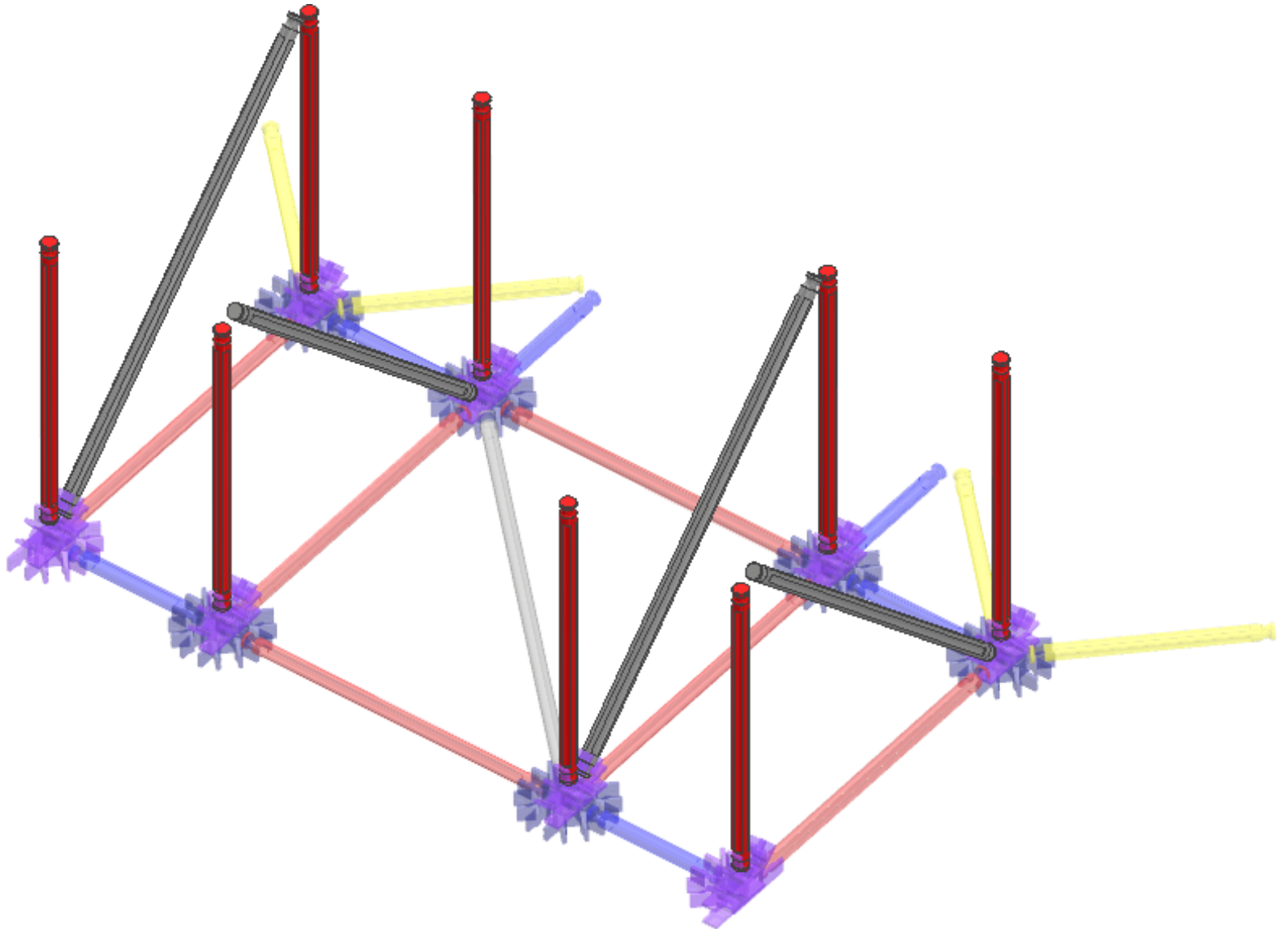

B3

Build and attach top piece

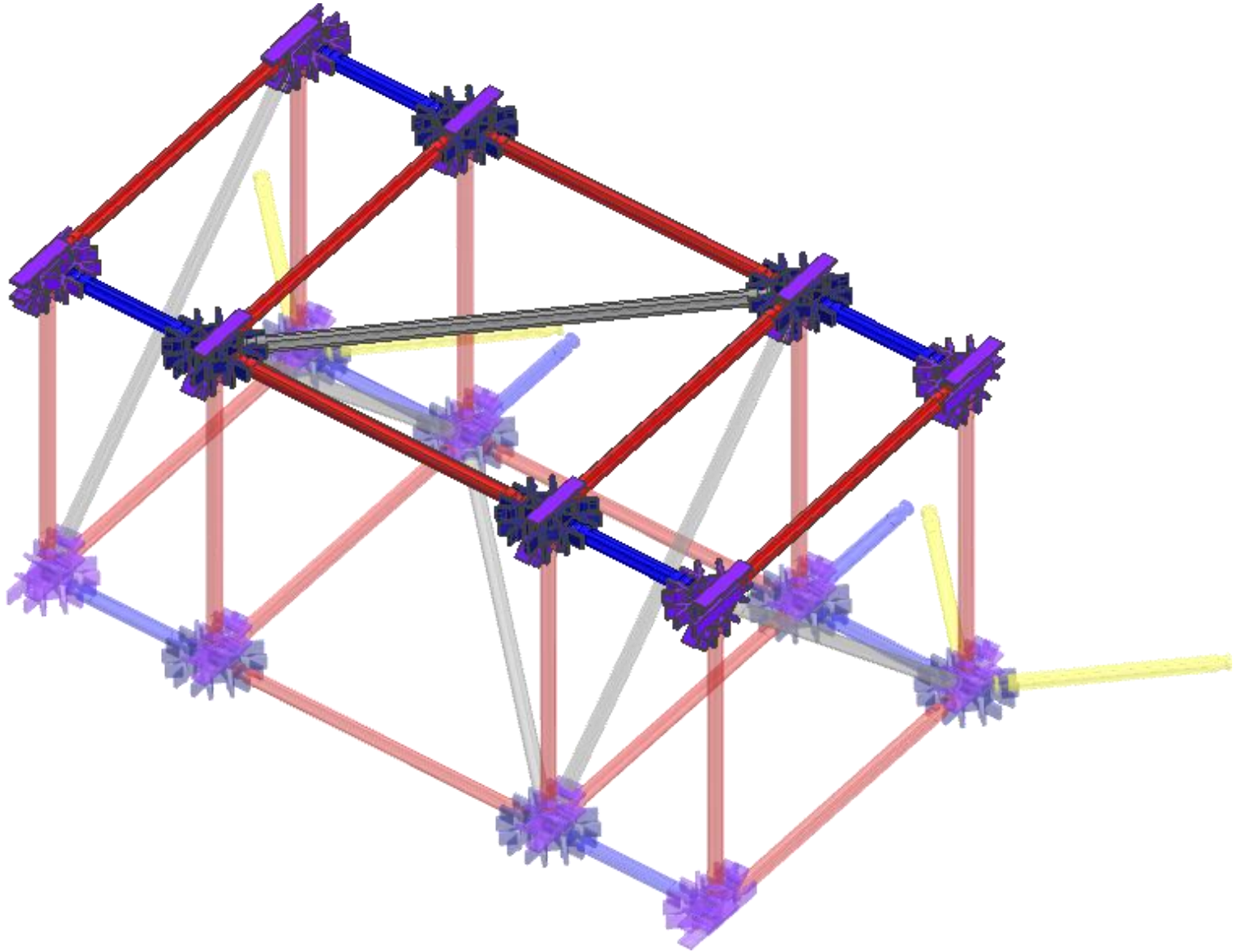

B4

Attach end piece to track

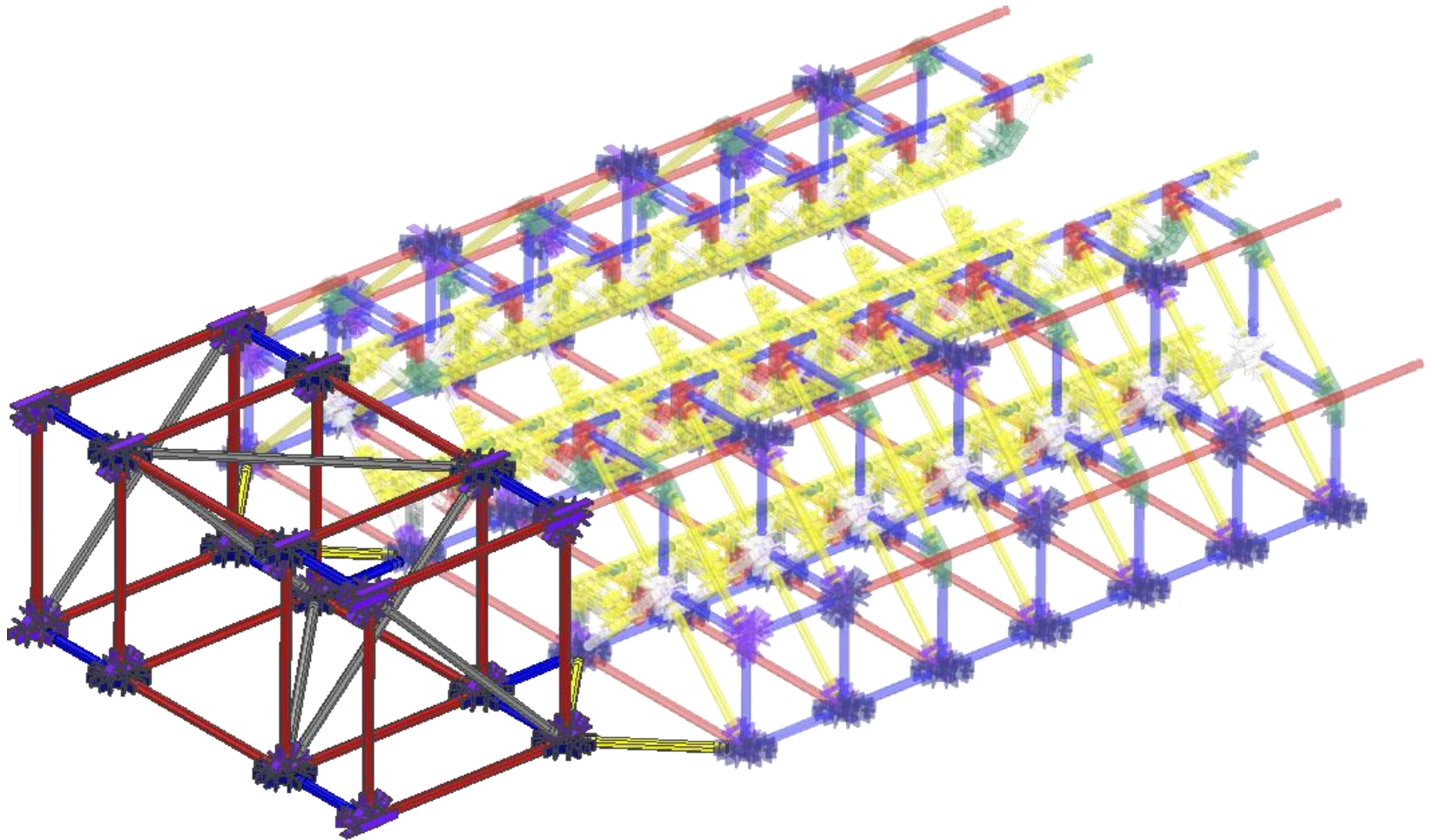

Part C: Cart

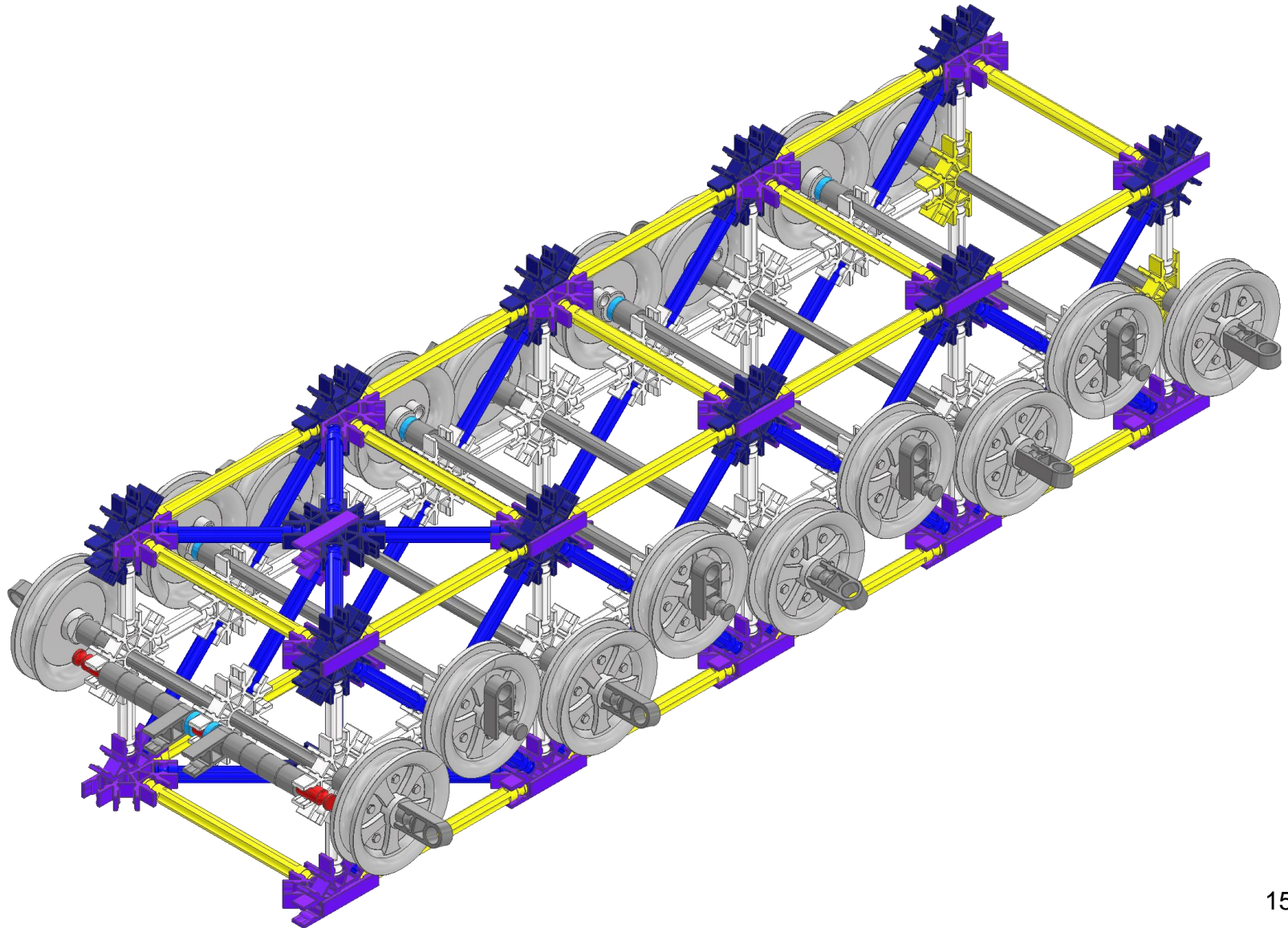

C1

Build cart sides

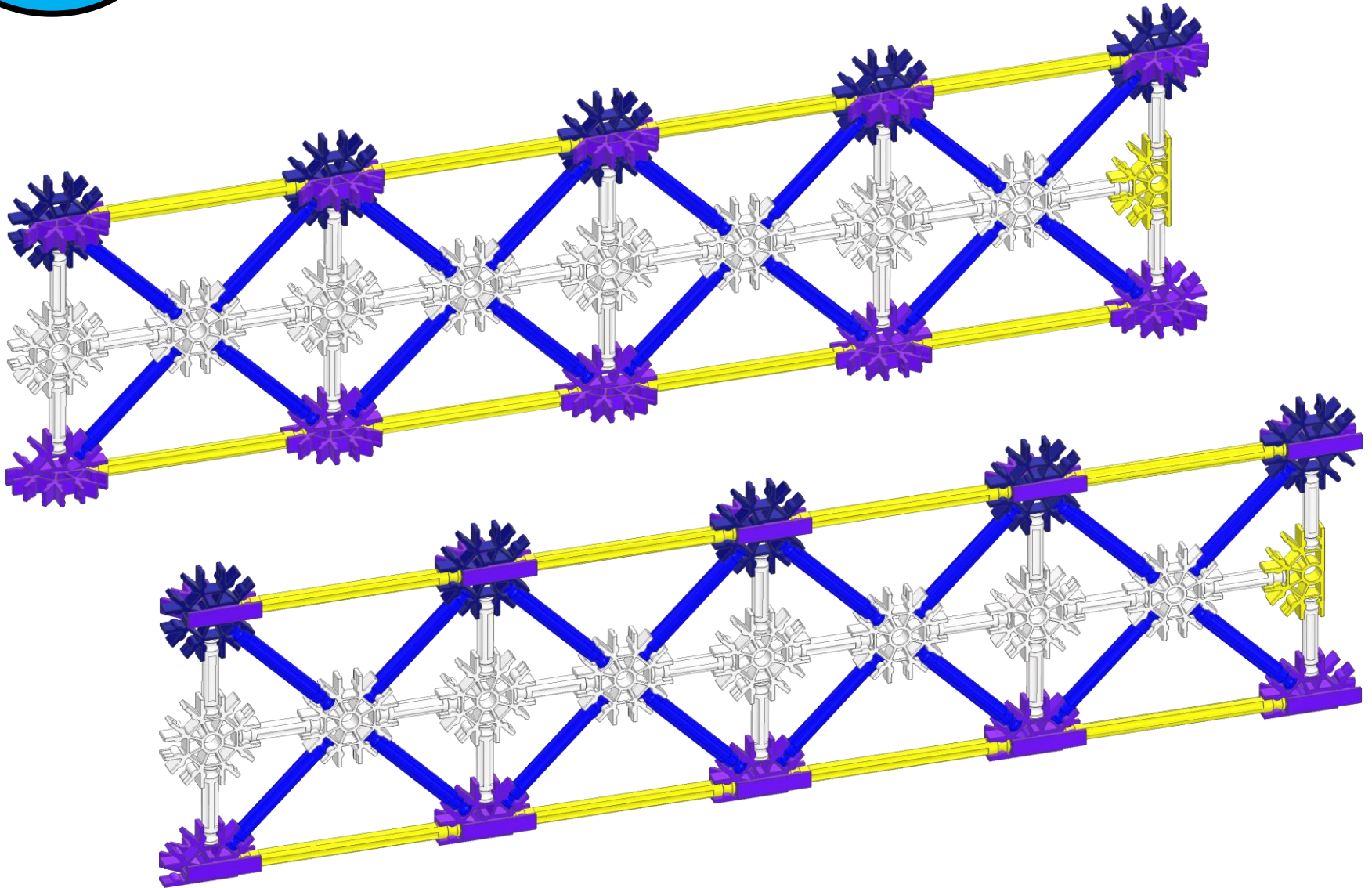

C2

Connect both sides together

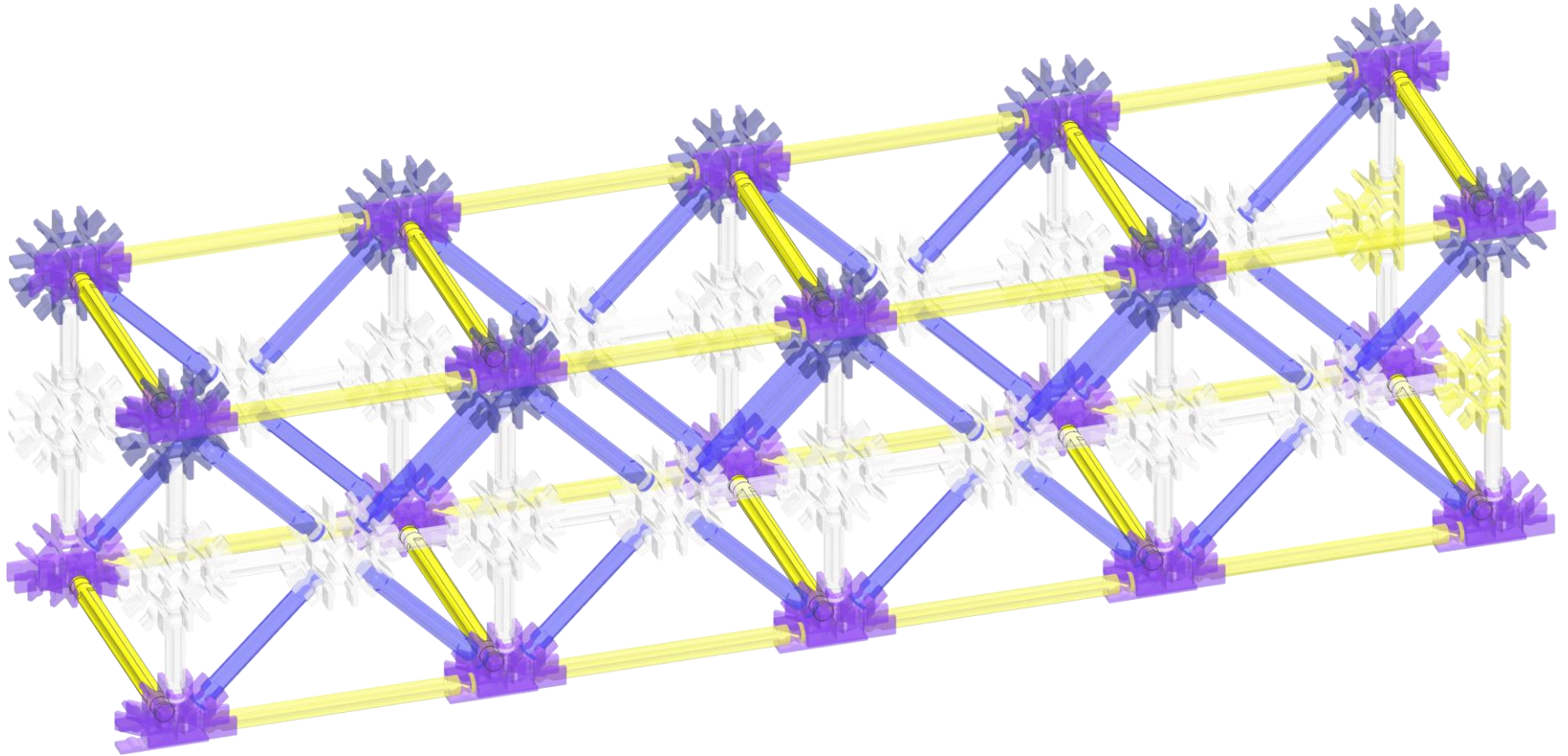

C3

Build and install reinforcement

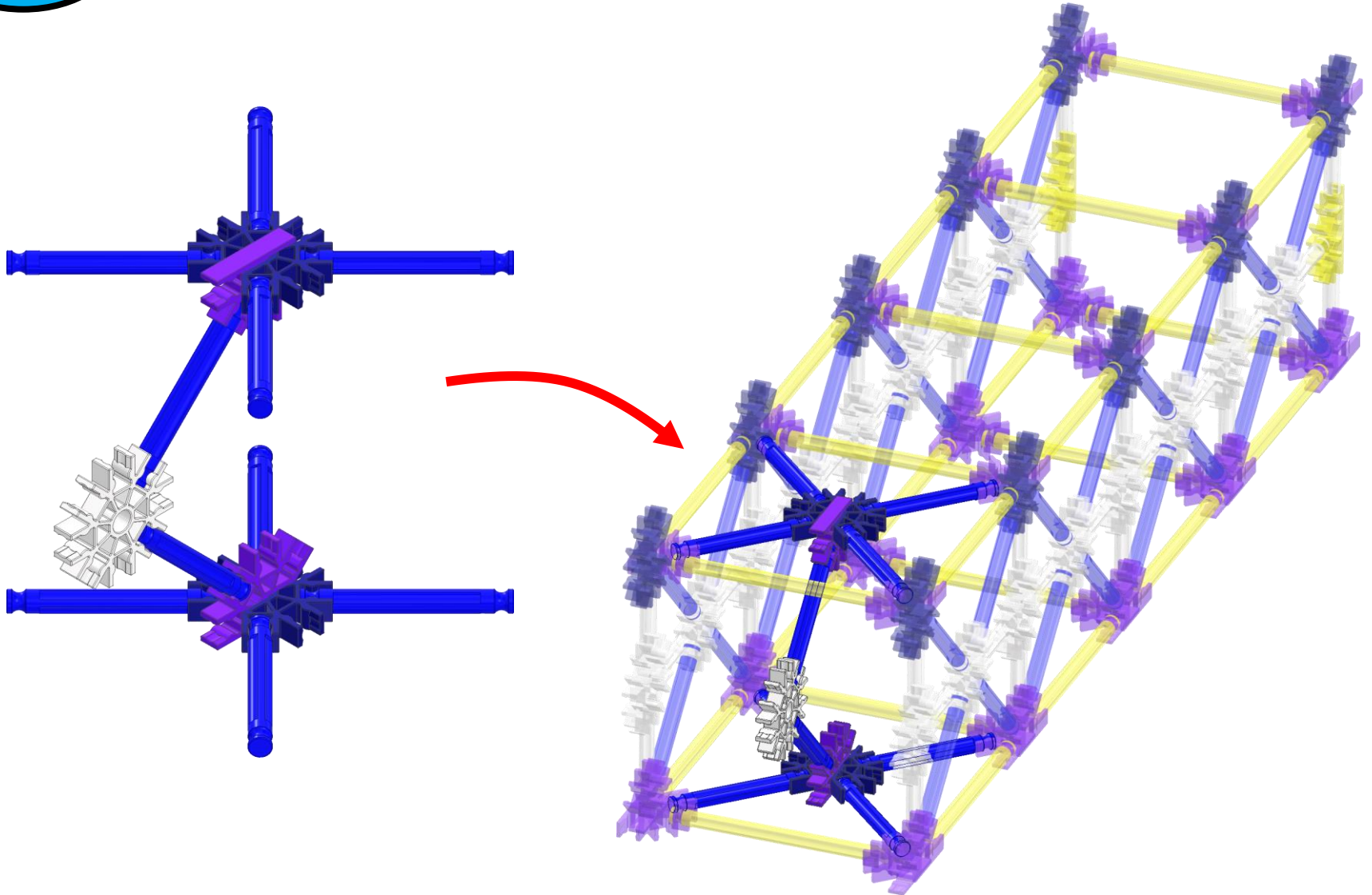

C4

Attach axles and spacers

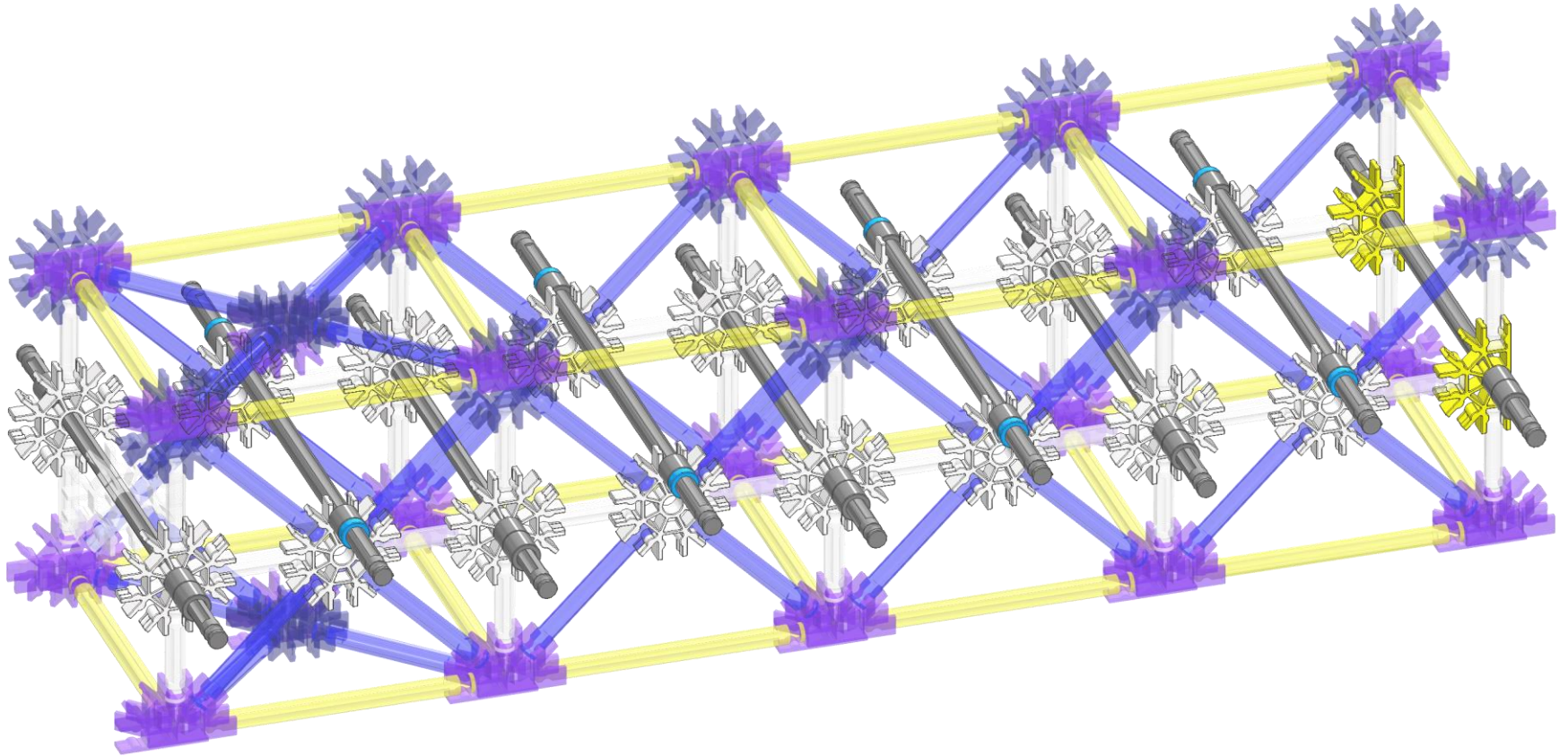

C5

Add wheels and secure with end clips

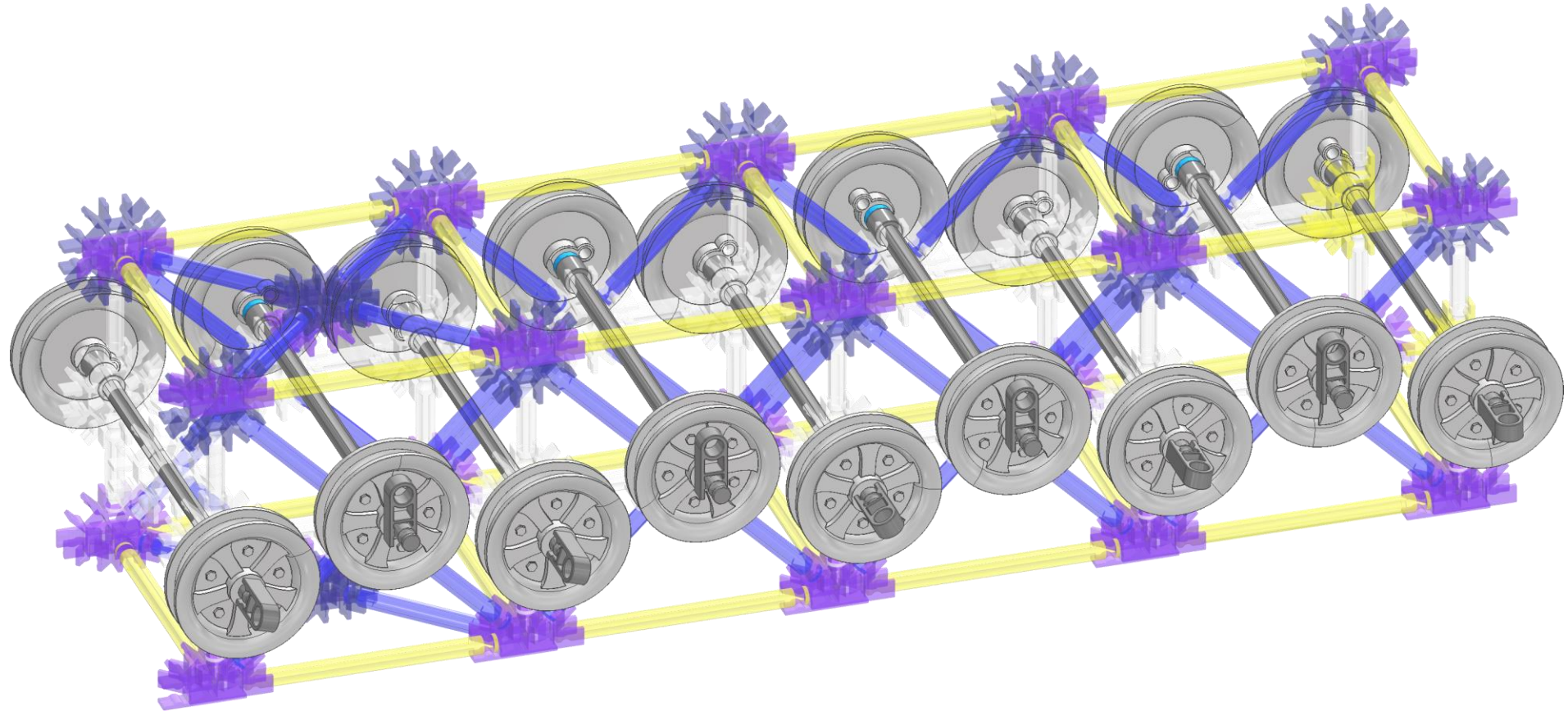

C6

Attach connection to crank

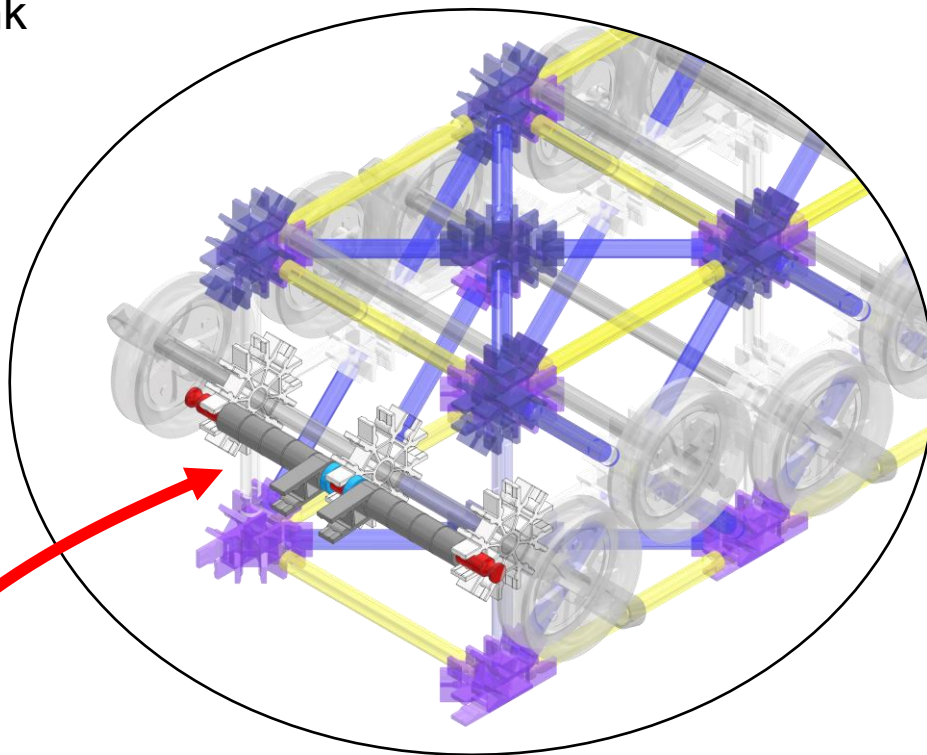
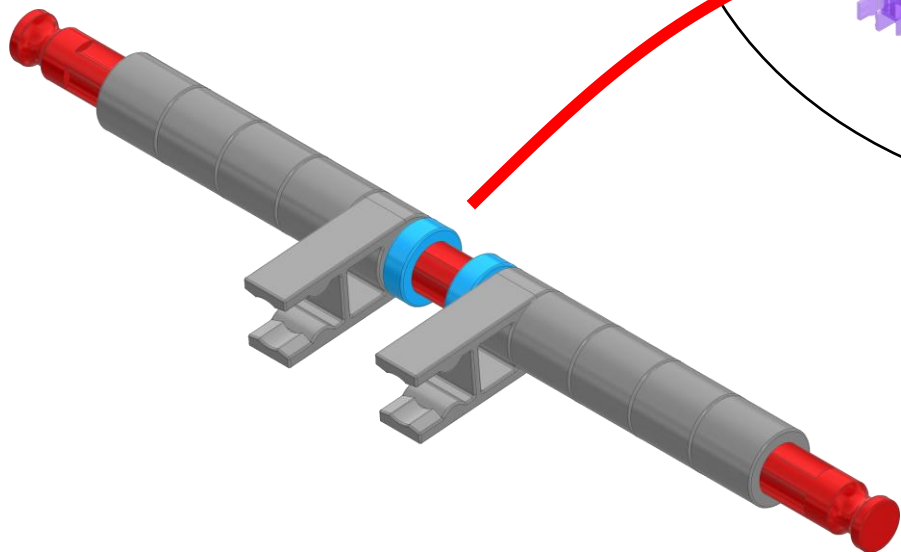

C7

Insert cart into track

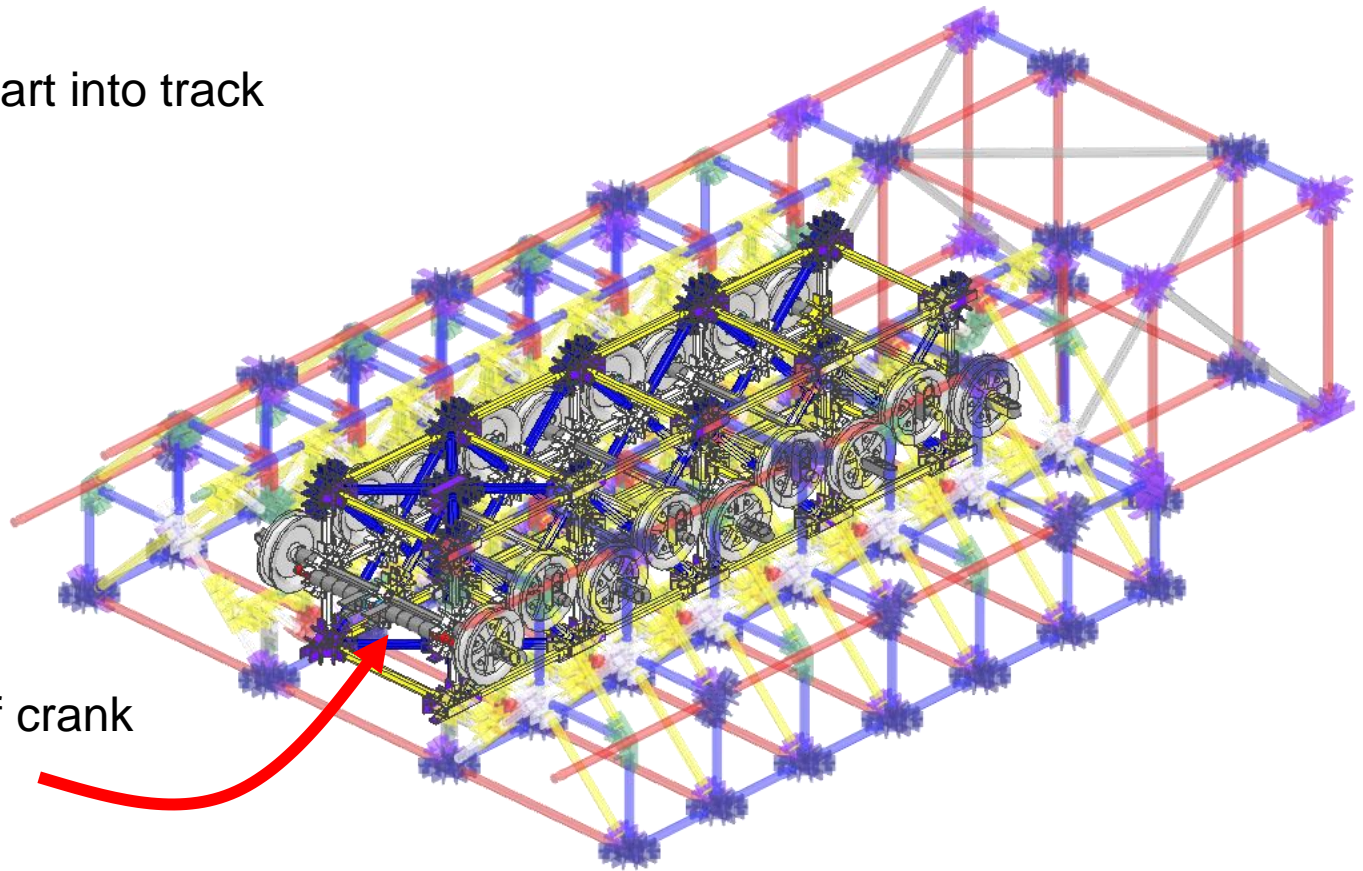

Note location of crank connection

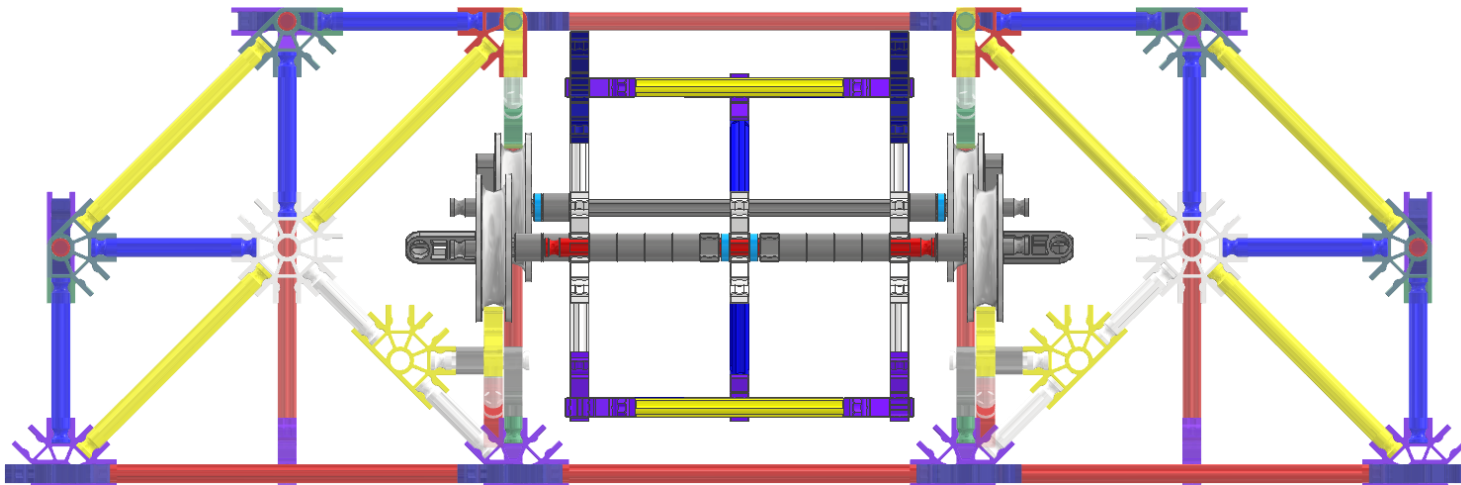

Part D: Gear Box

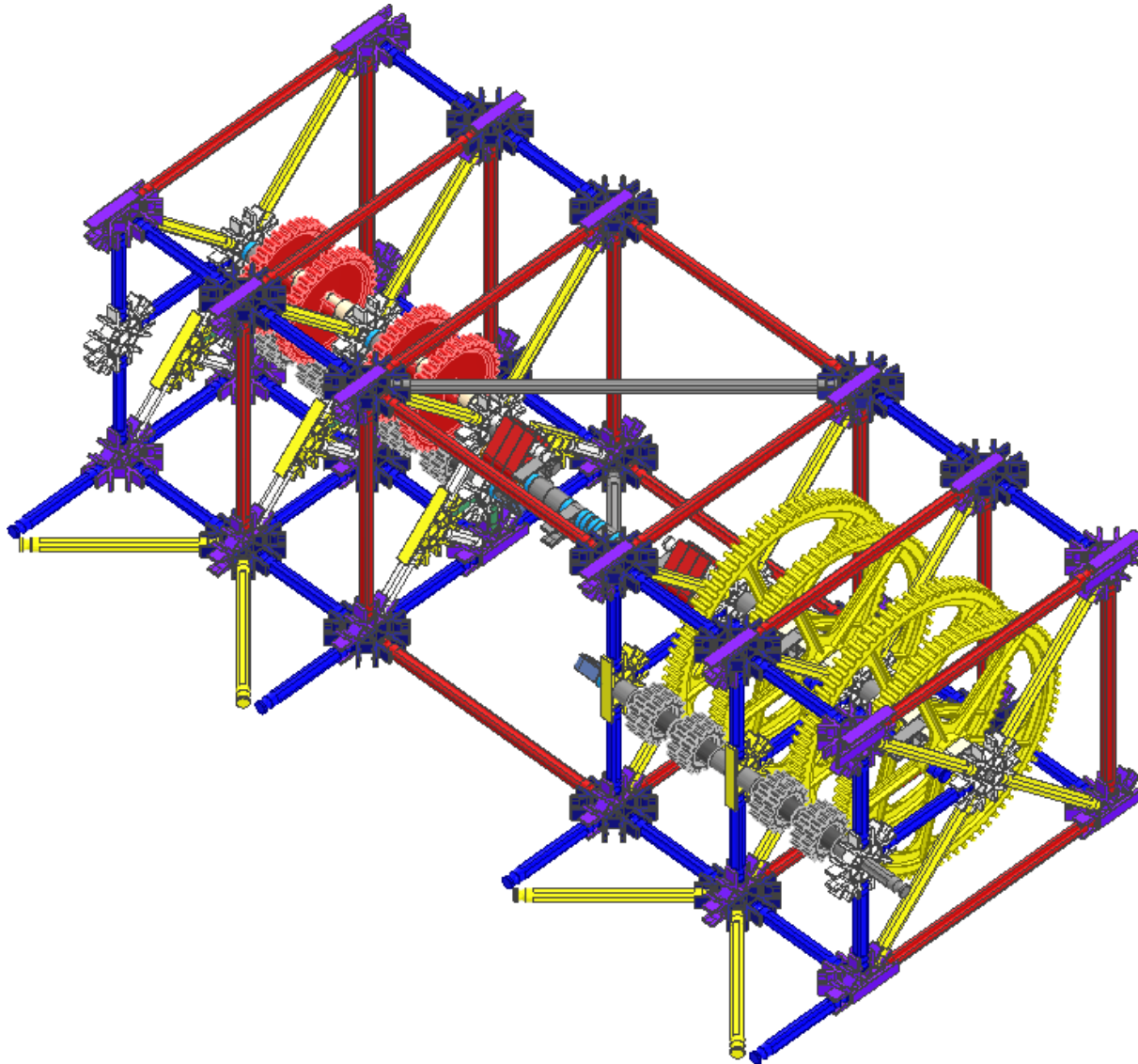

D1

Build base

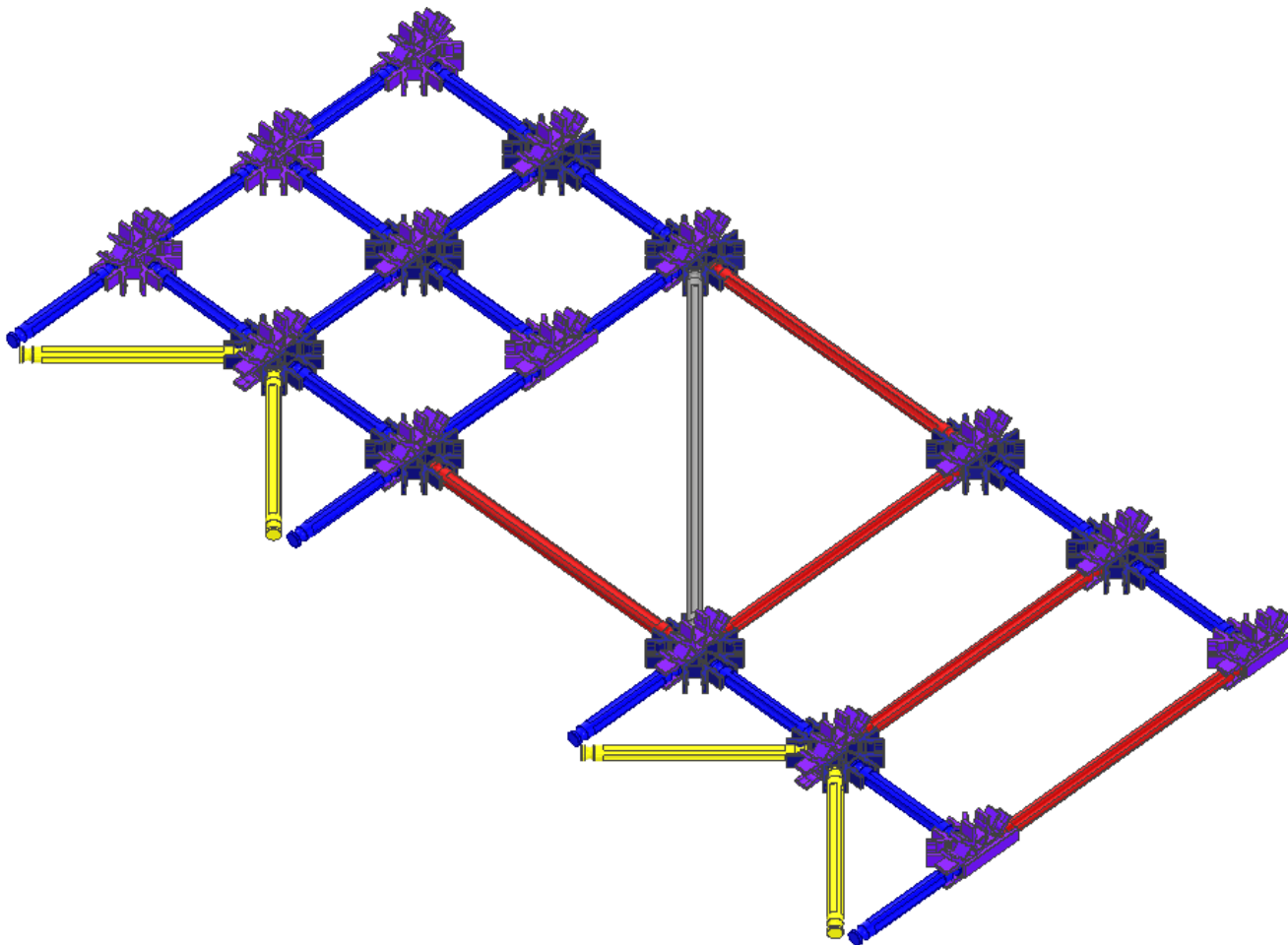

D2

Build and attach gear assembly guides

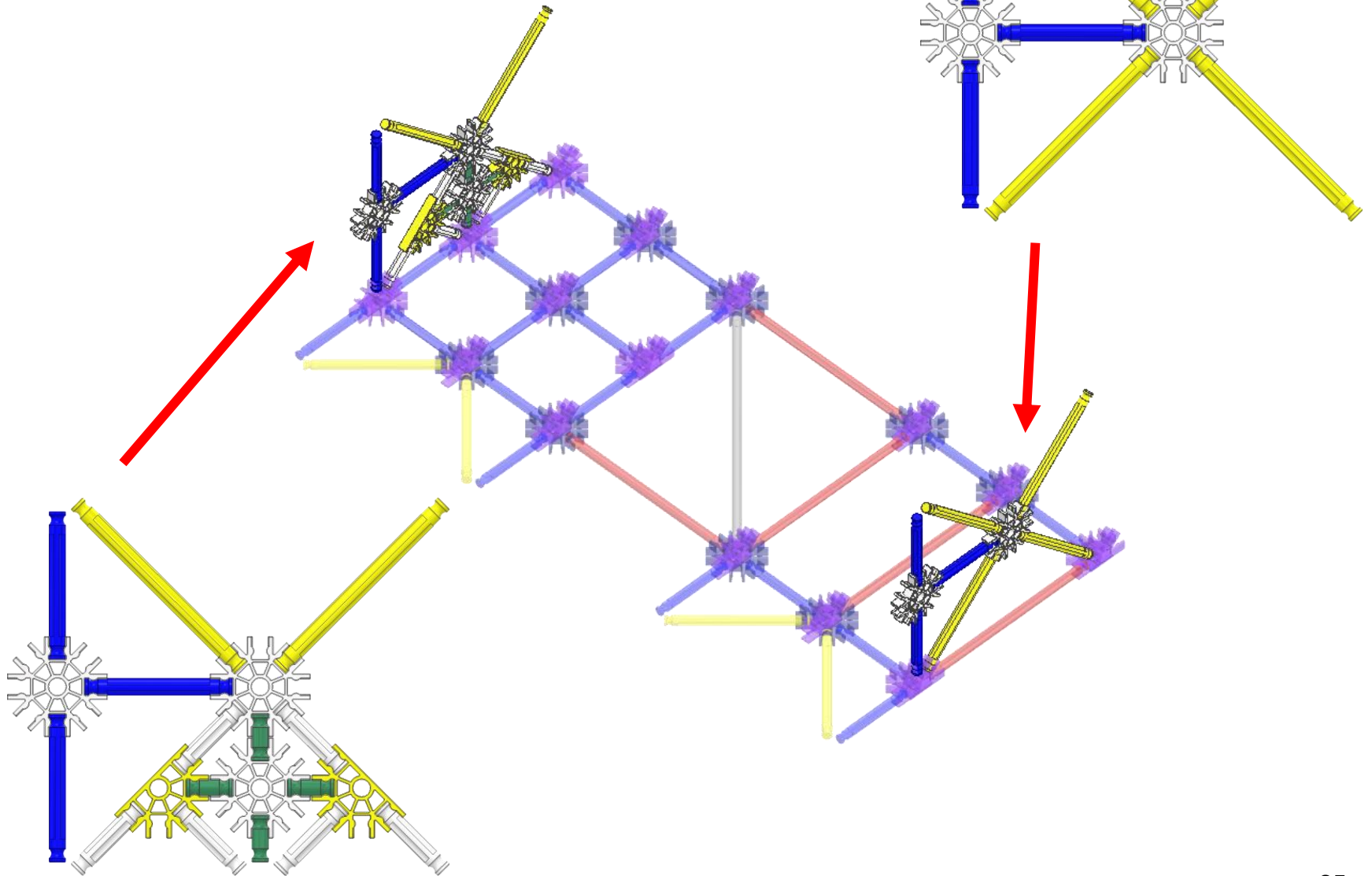

D3

Build and install high-gear drive

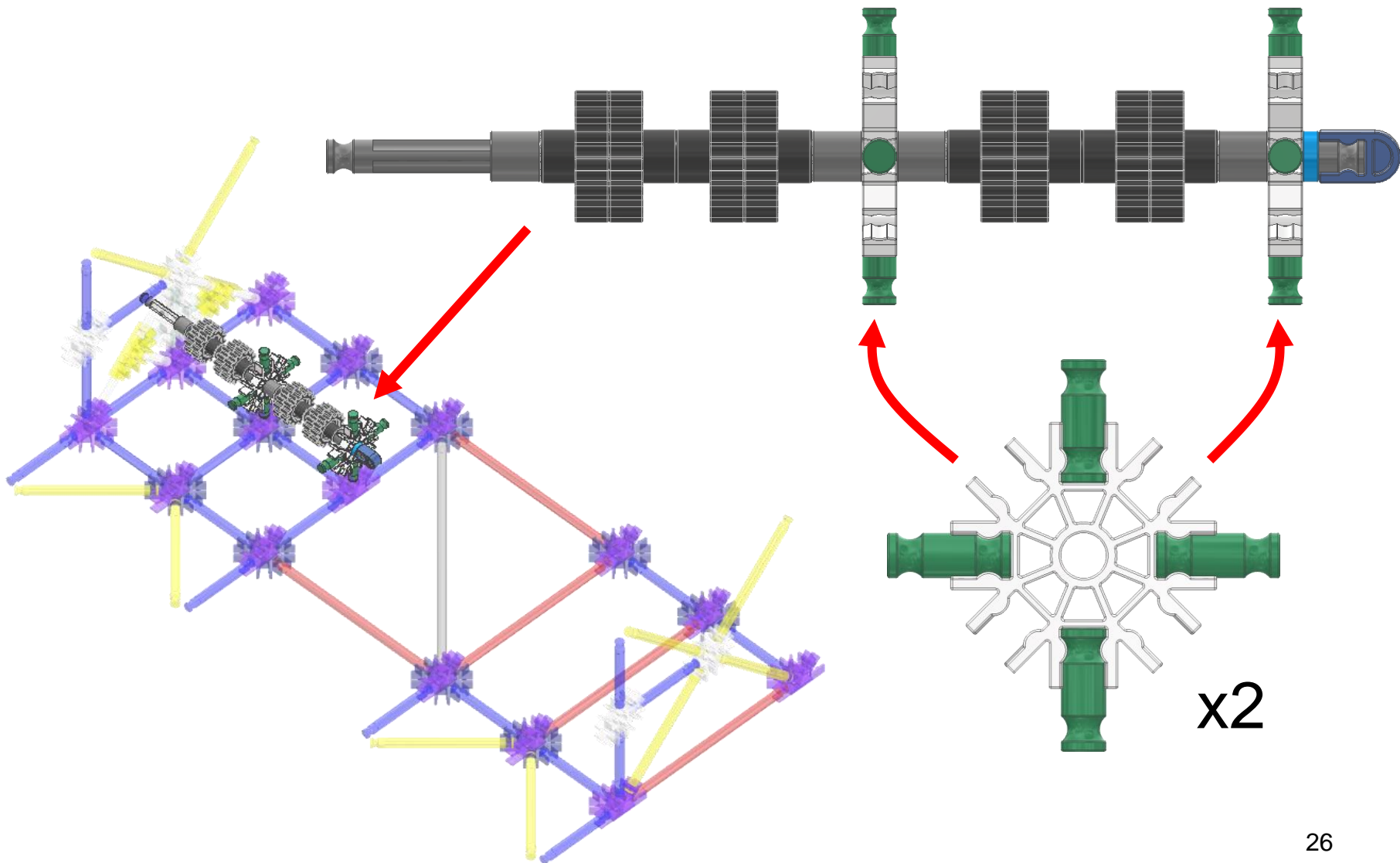

D4

Build and install low-gear drive

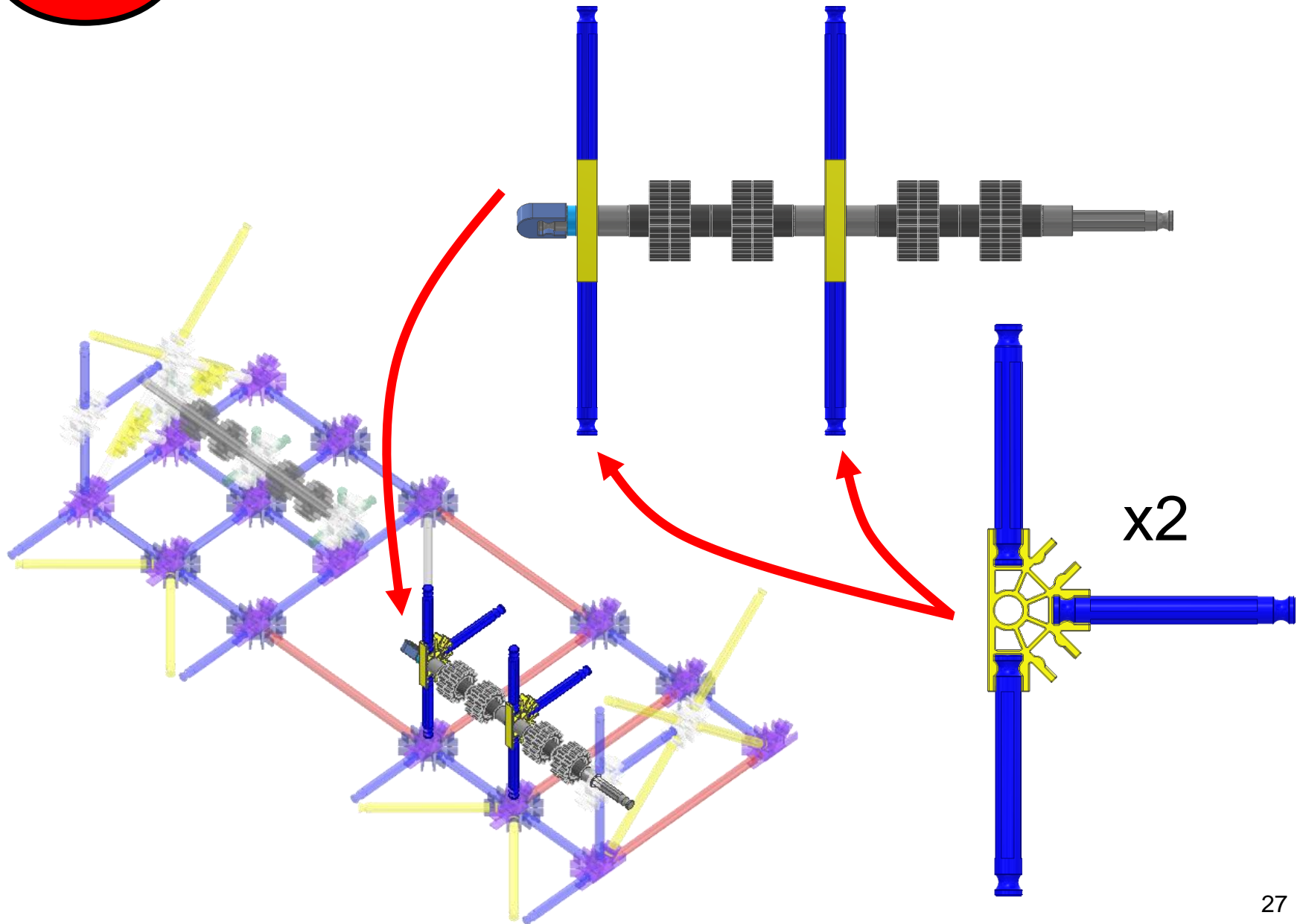

D5

Build red and yellow gear assembly axles

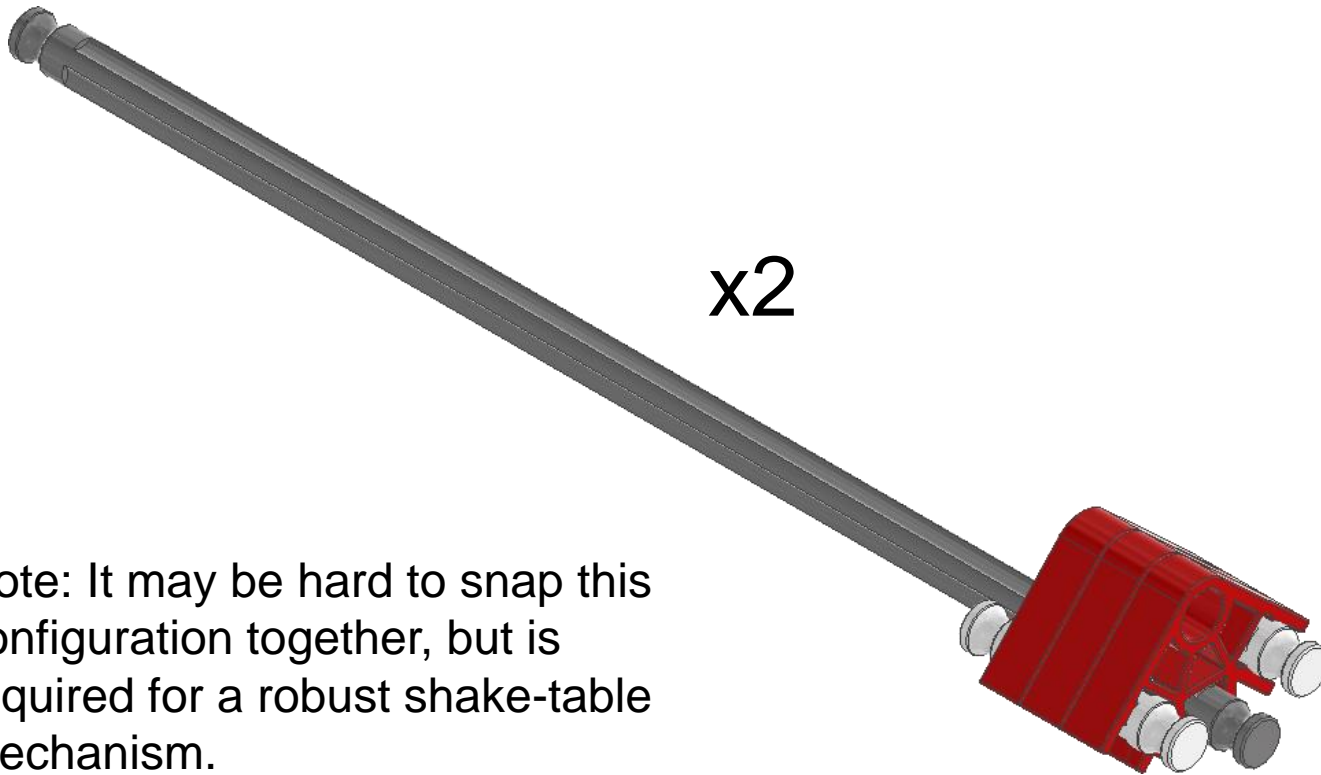

Note: It may be hard to snap this configuration together, but is required for a robust shake-table mechanism.

D6

Build and install red gear assembly

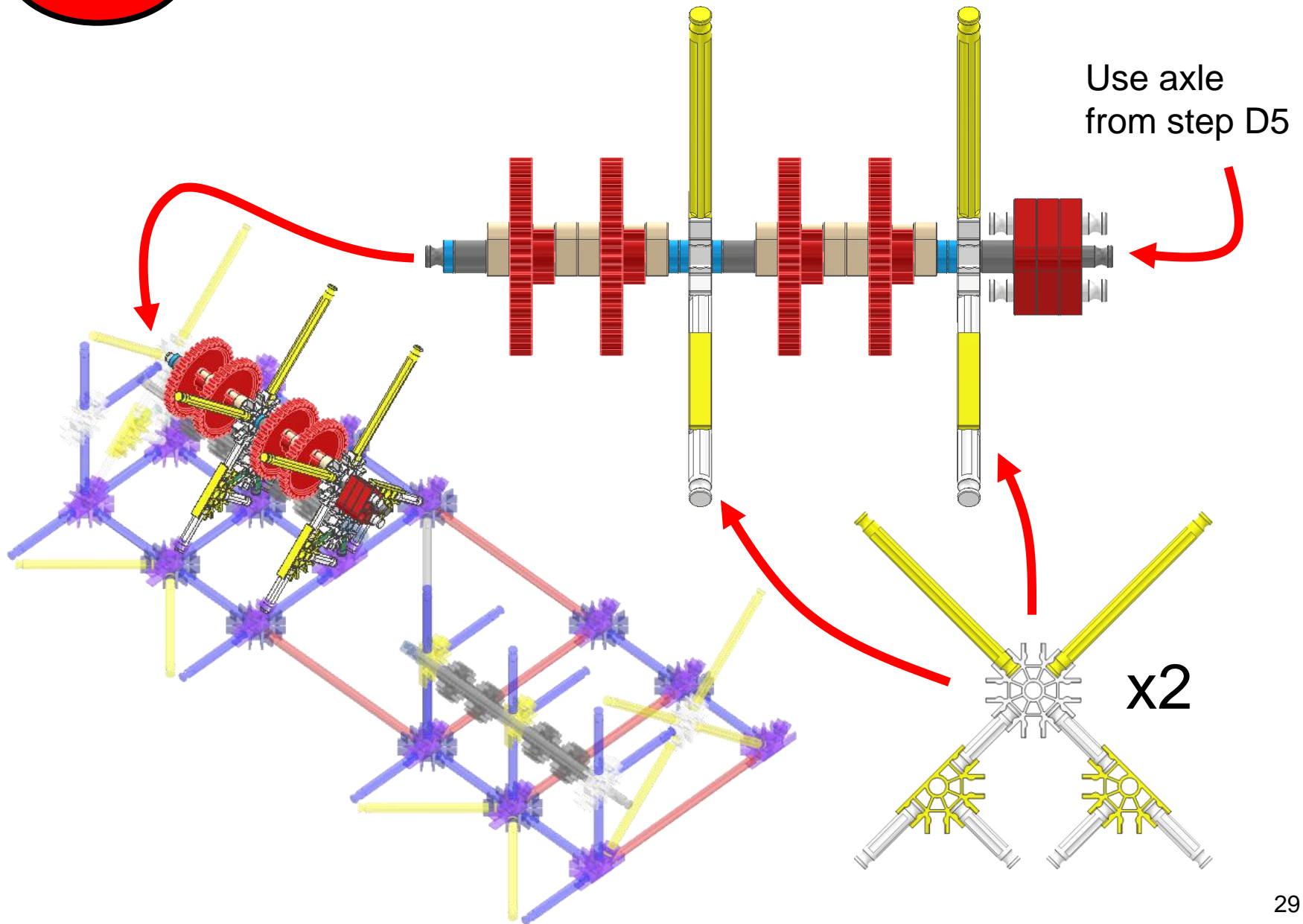

D7

Build and install yellow gear assembly

Use axle
from step D5

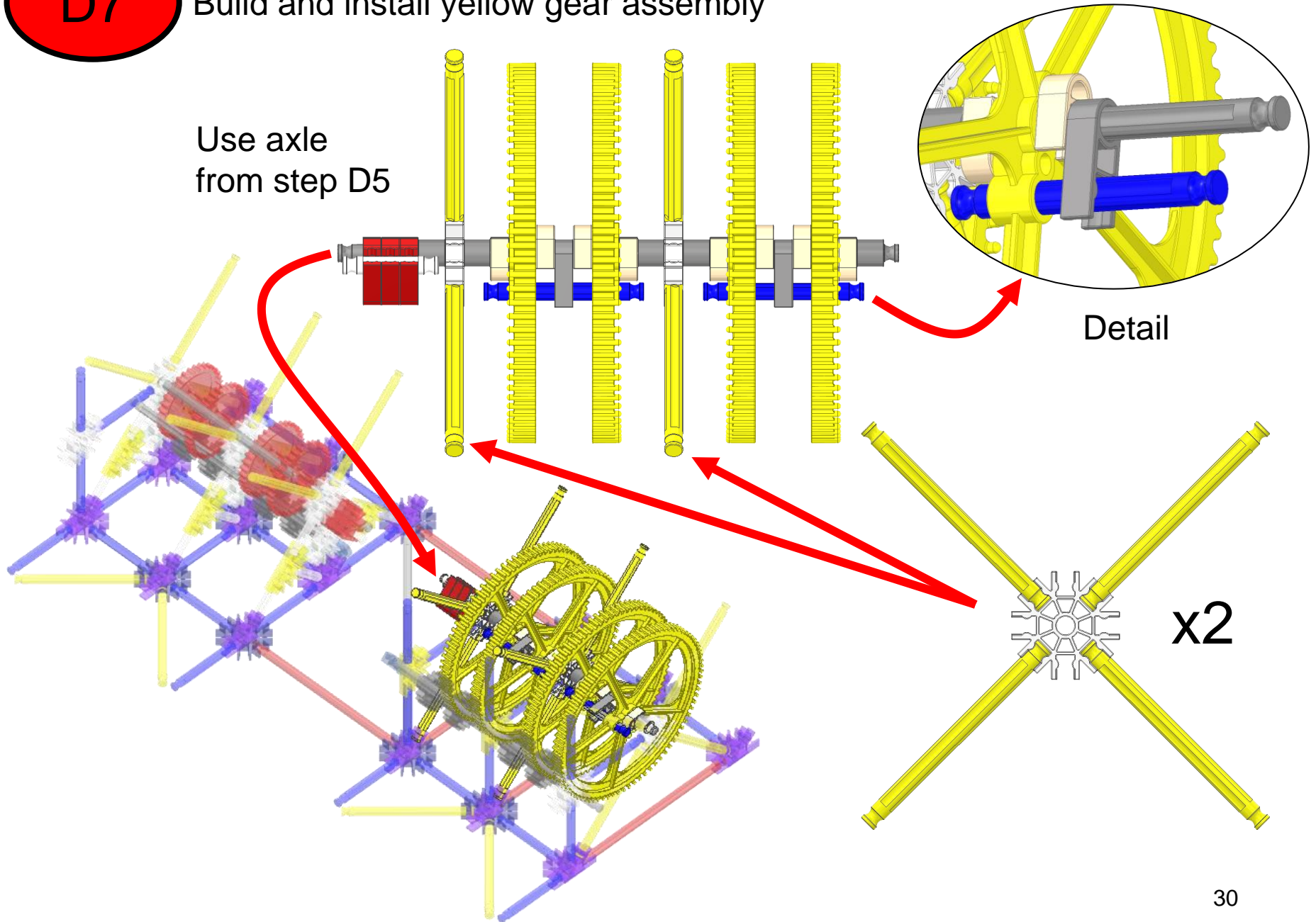

Detail

x2

D8

Build and install crank

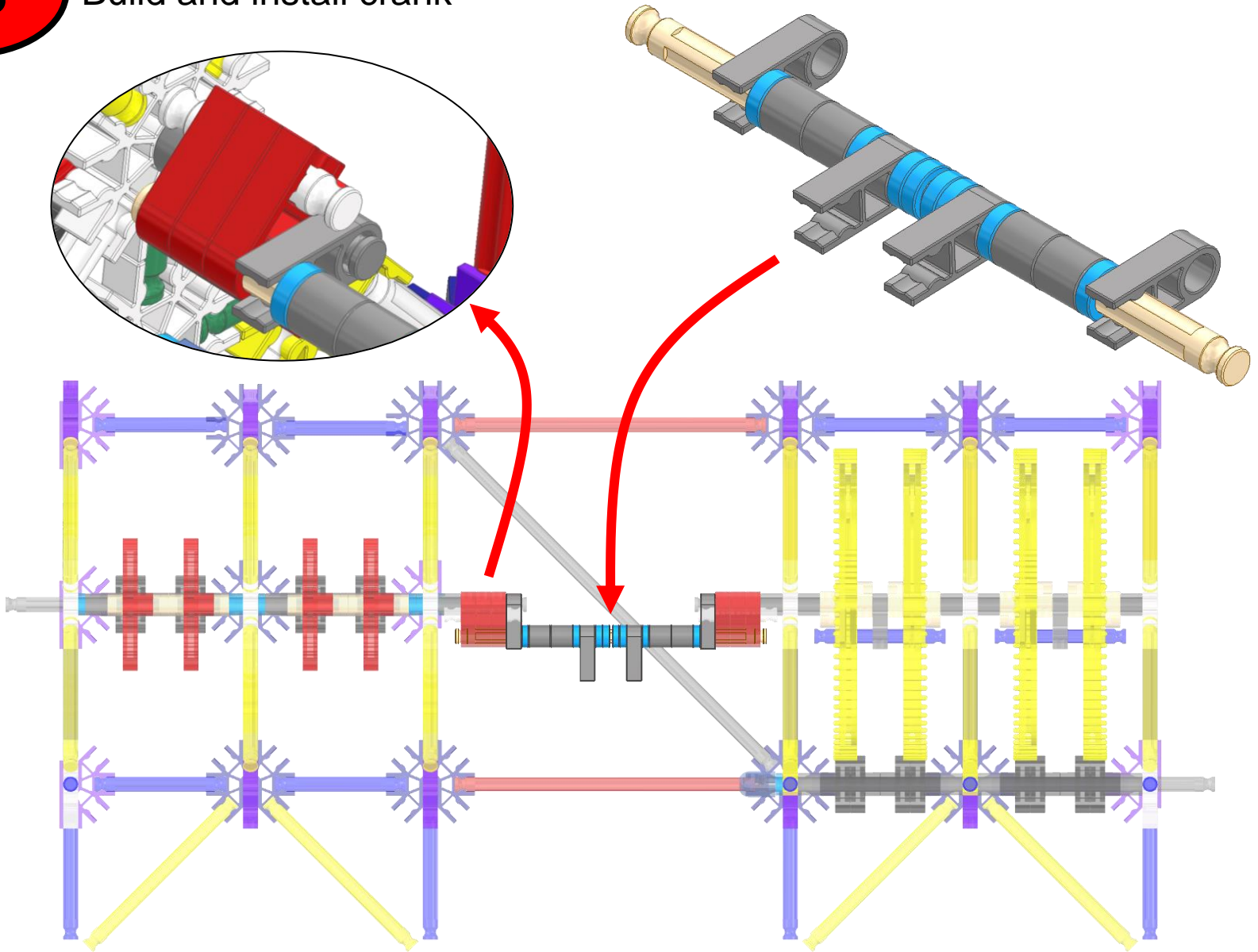

D9

Build and install gear box cover

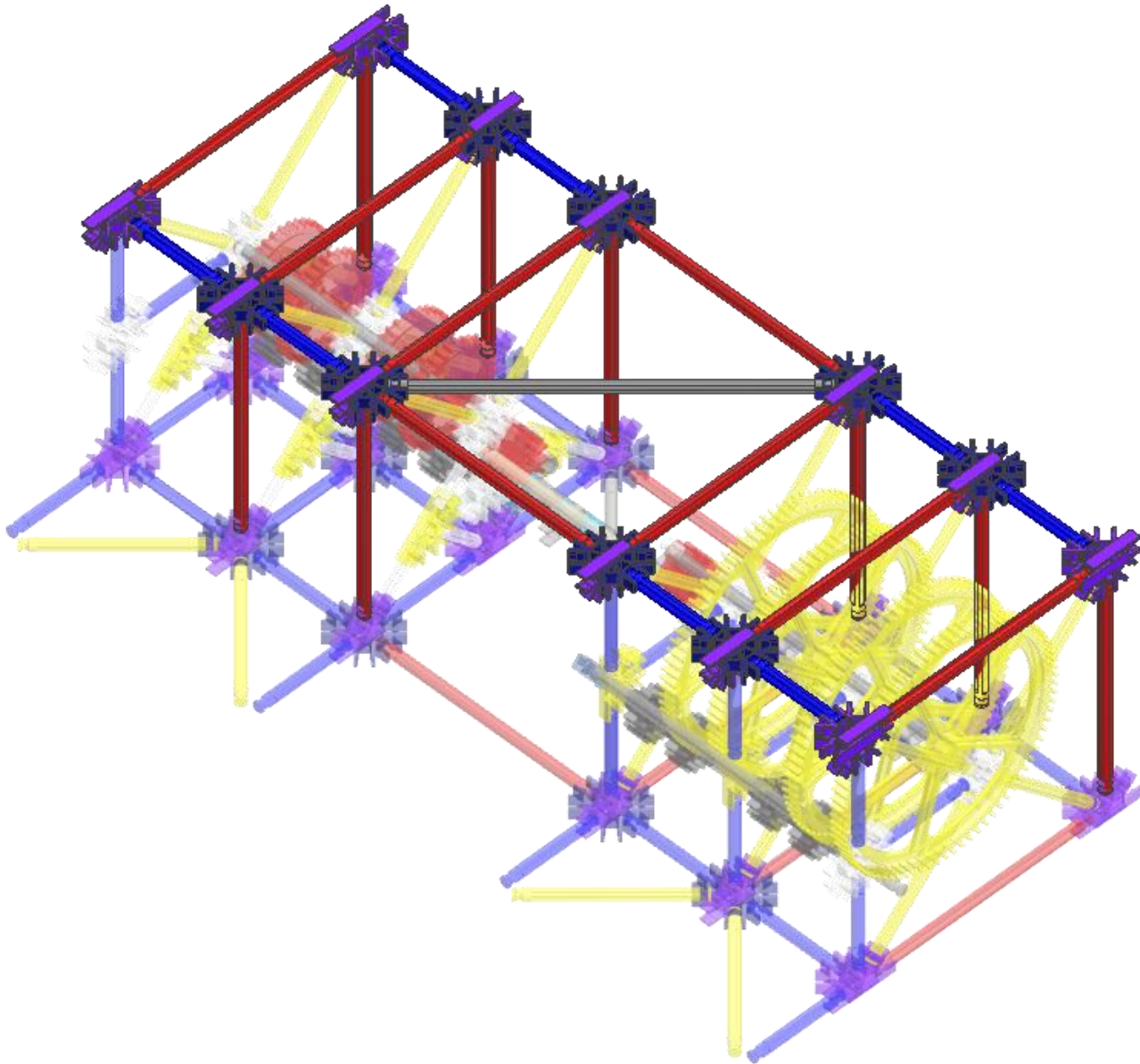

D10

Attach gear box to track

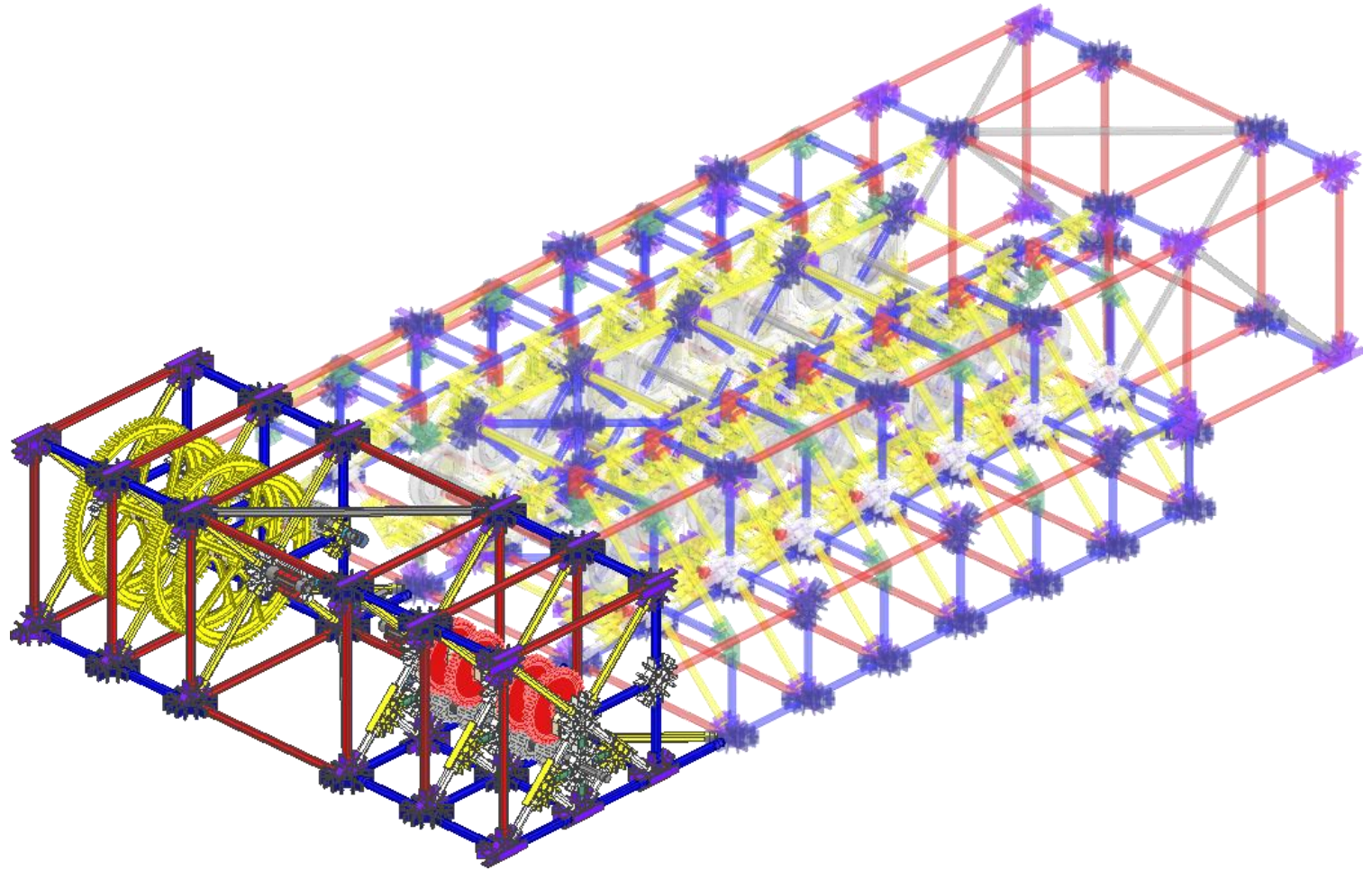

D11

Attach connecting rods for crank mechanism

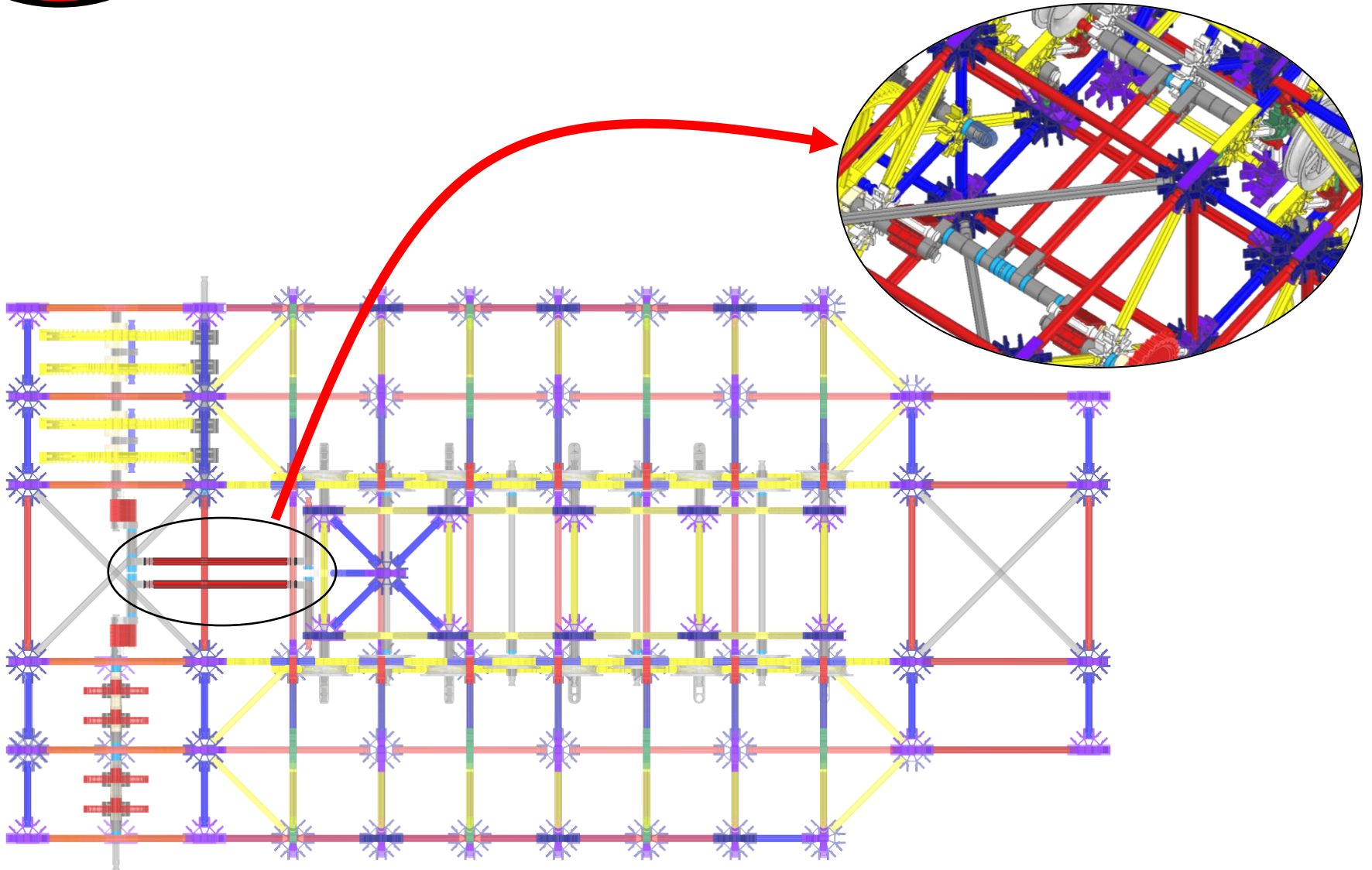

Part E: Tower

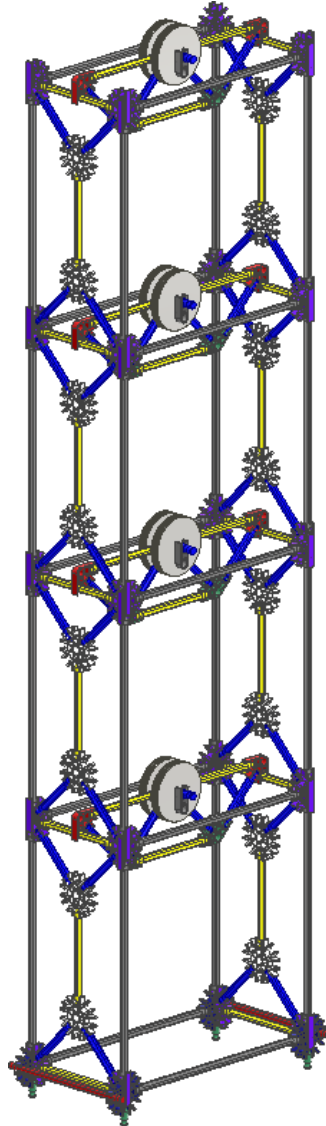

E1

Build tower base

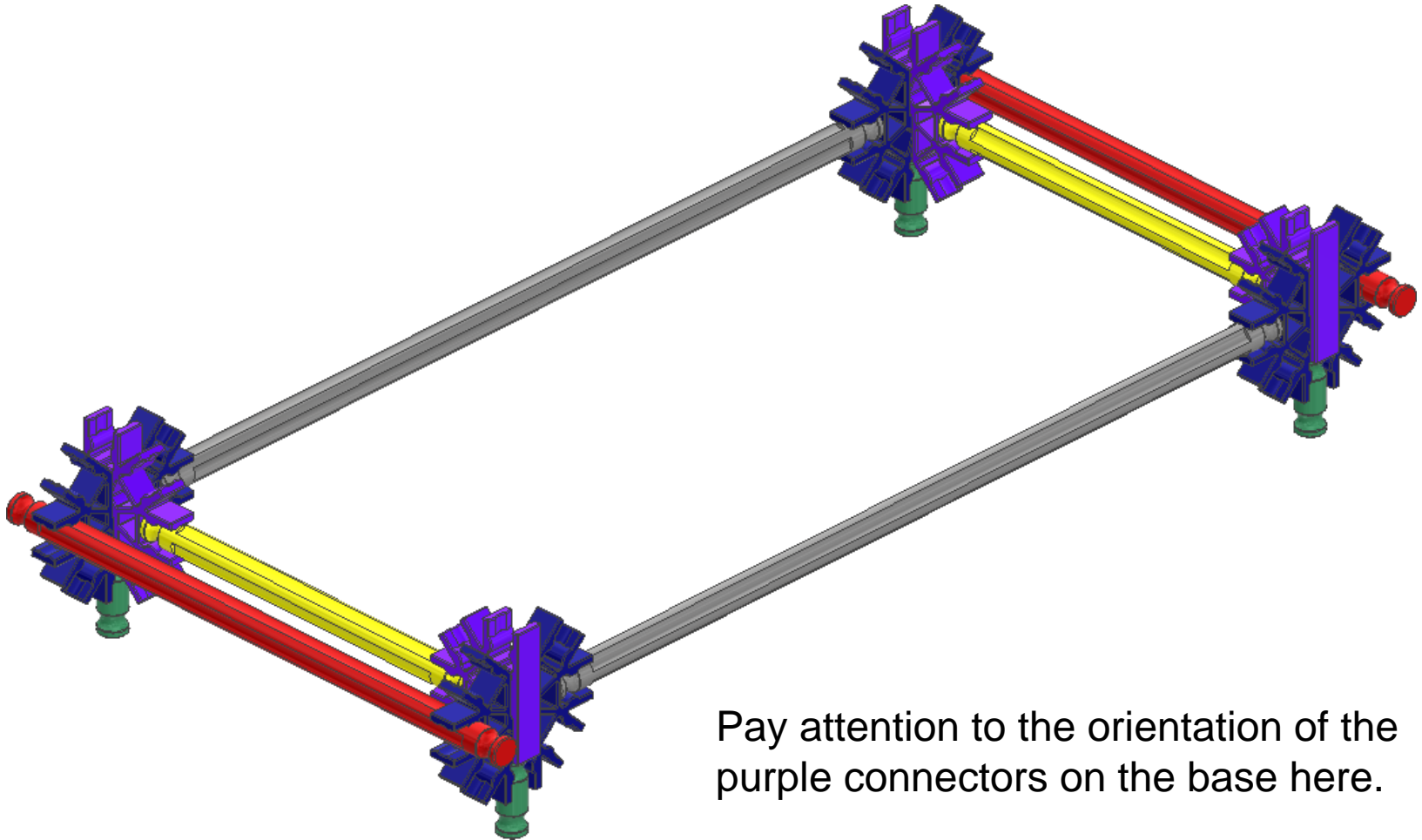

Pay attention to the orientation of the purple connectors on the base here.

E2

Build frame(s) for tower levels

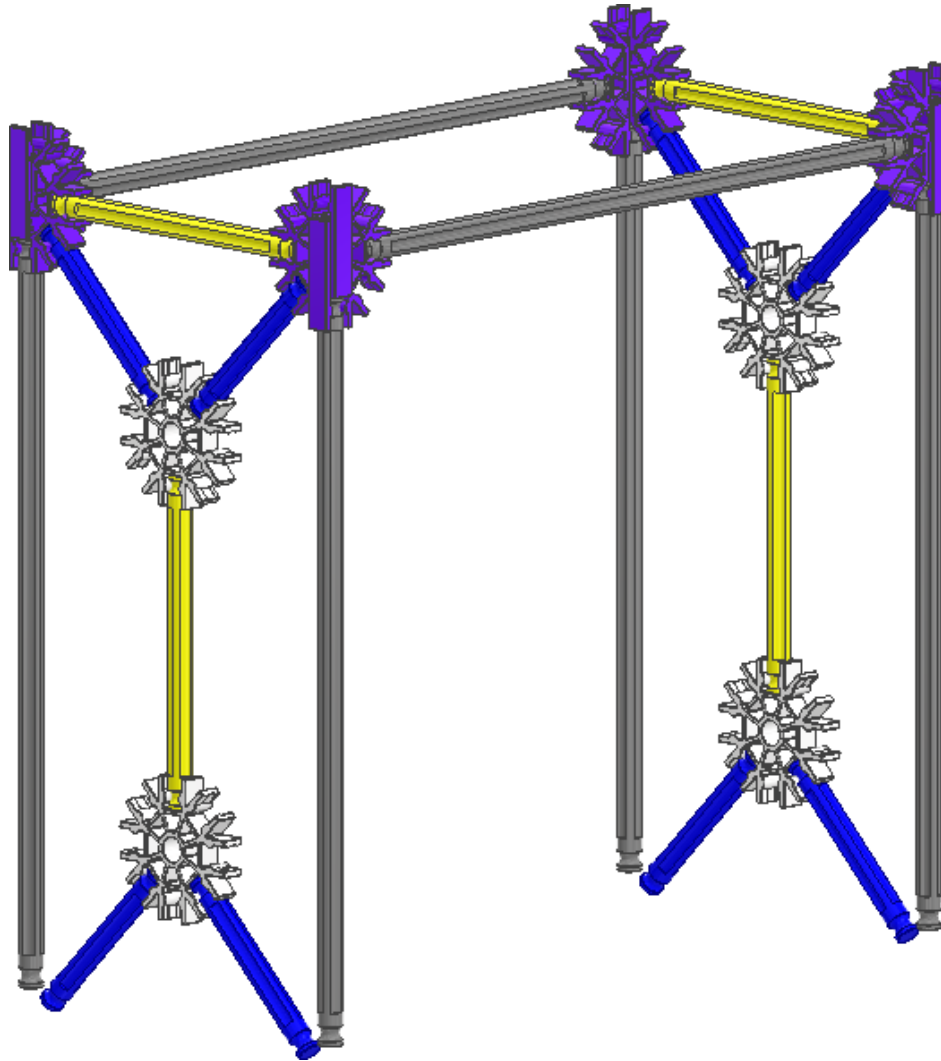

E3

Build hangar(s) for masses and attach masses

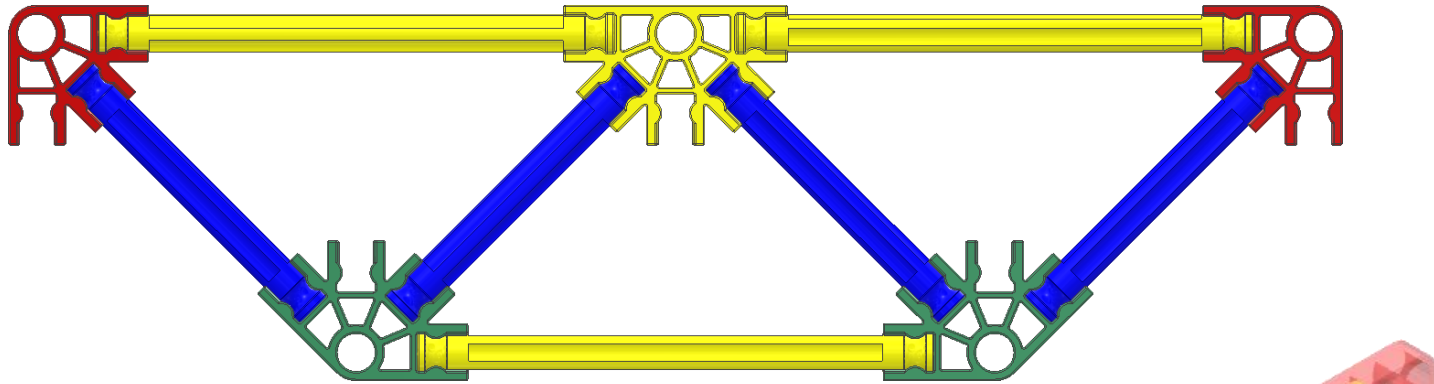

Add as few or as many washers as you like.

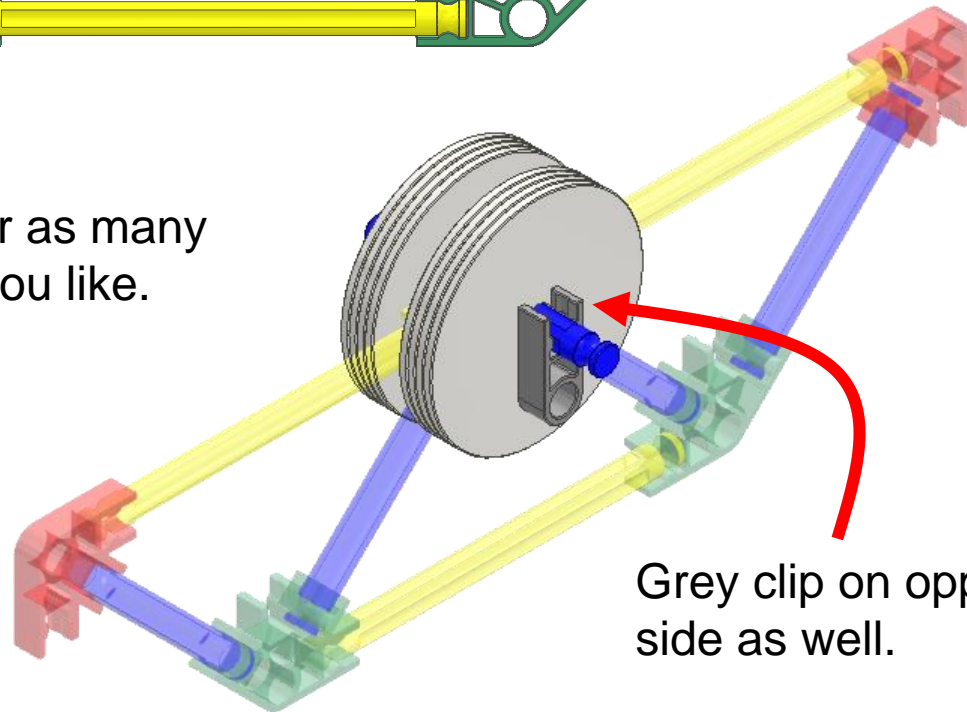

Grey clip on opposite side as well.

E4

Install mass hangars

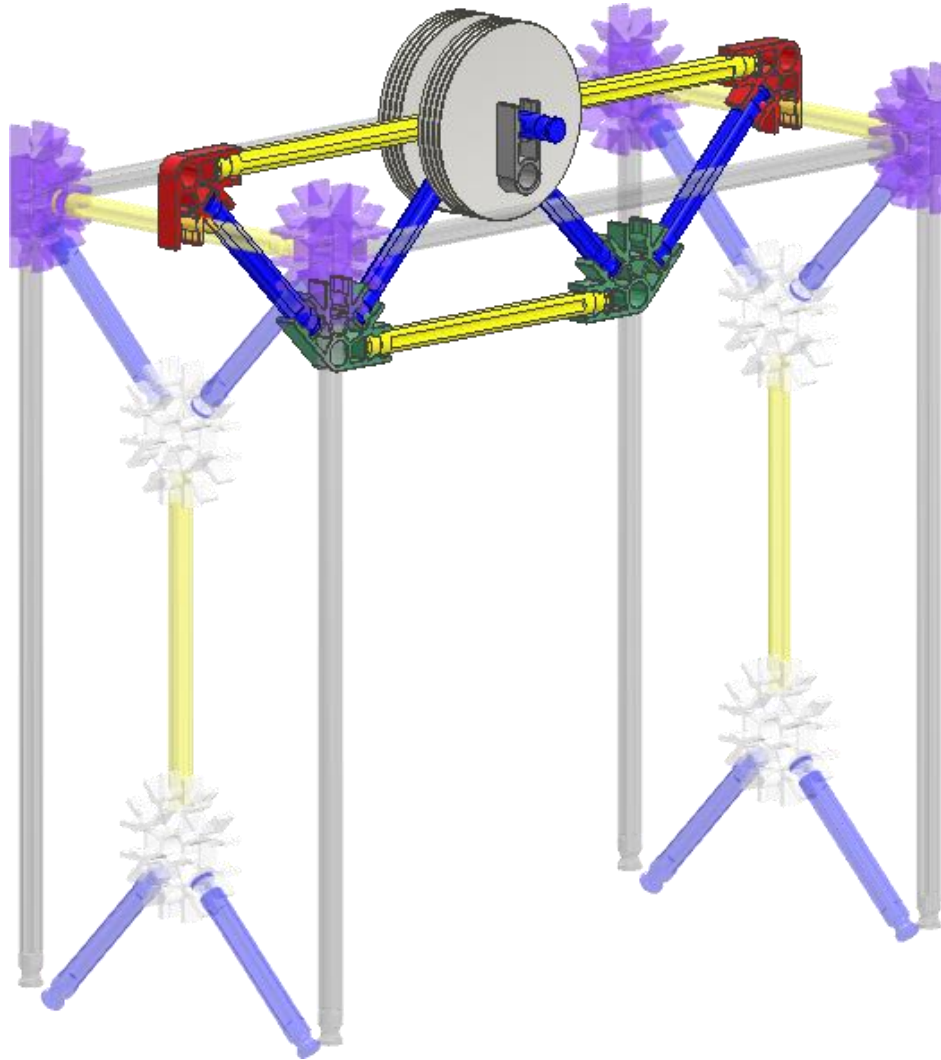

E5

Attach first floor to base

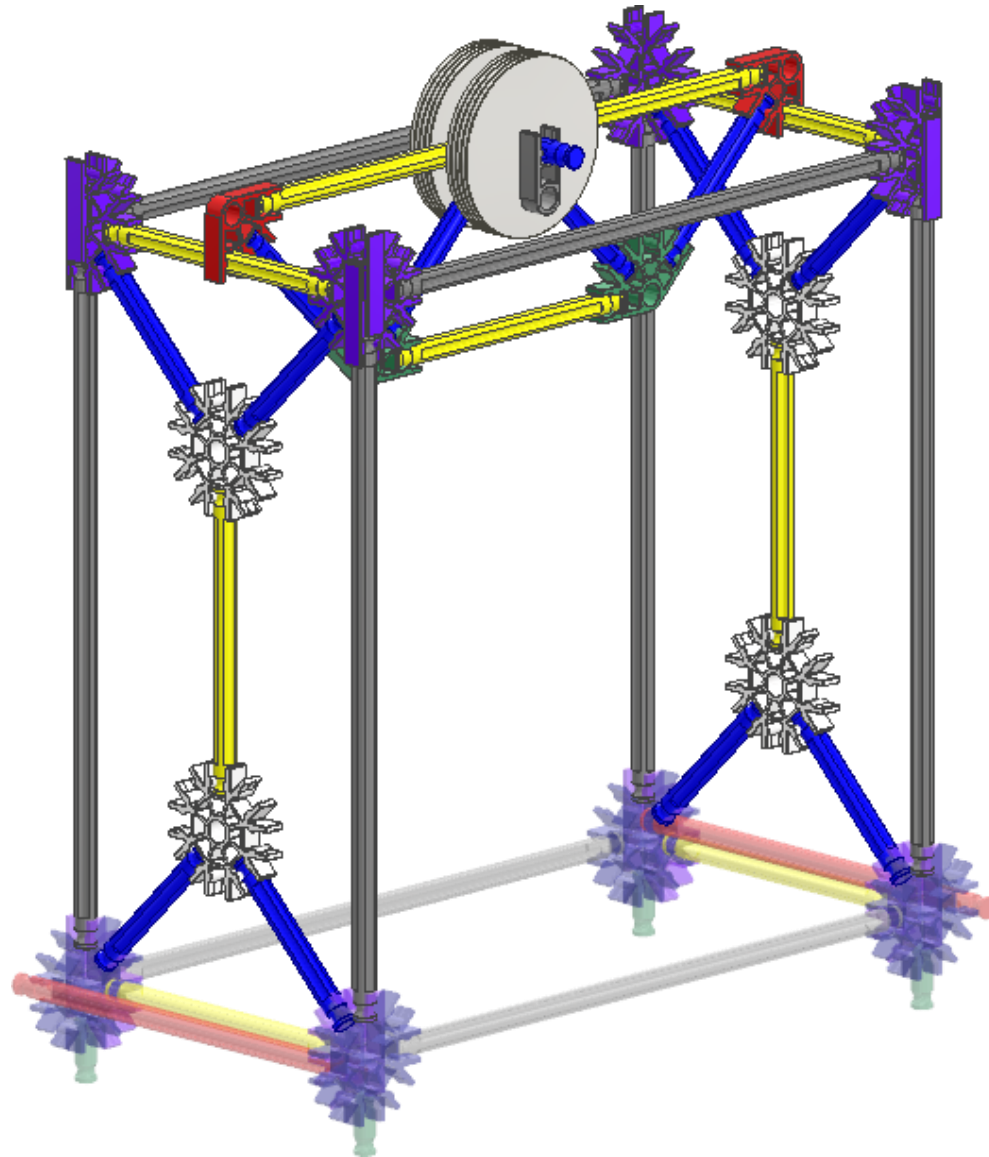

E6

Attach additional floors

For taller buildings,
just add more levels.

Also, feel free to
experiment with
different types of
bracing systems!

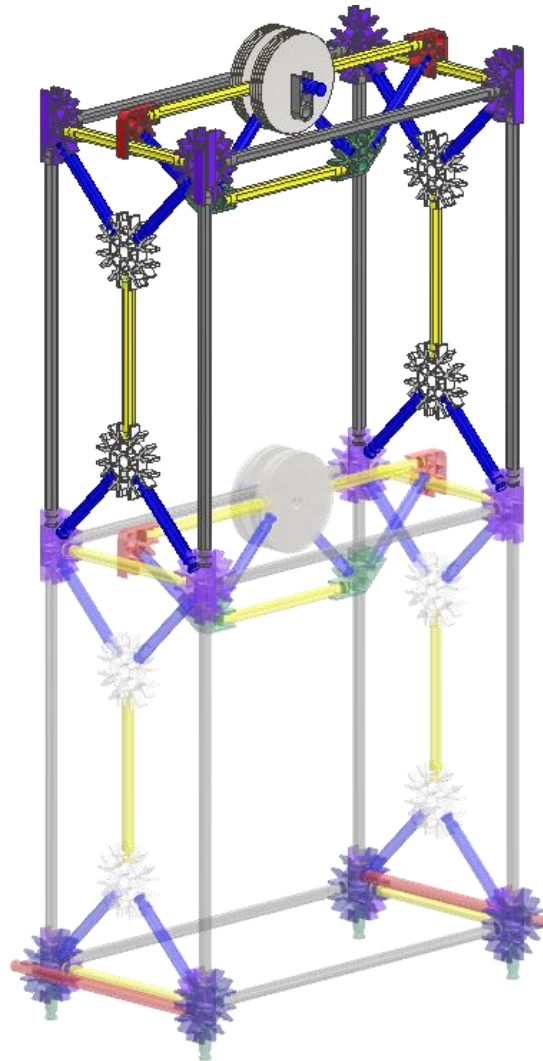

E7

Attach tower to cart

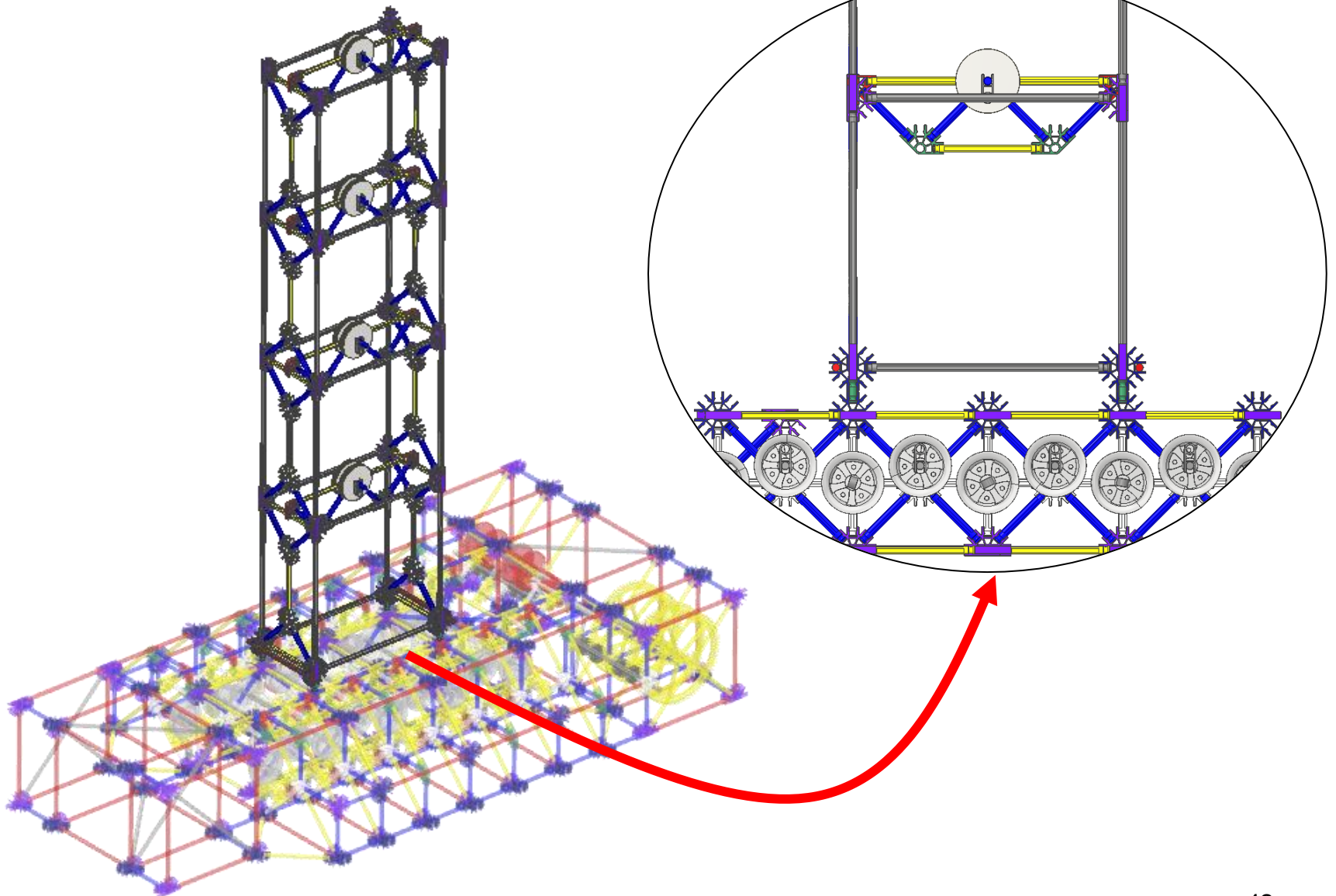

Operation of shake table:

Attach drill to grey rods on either side of shake table.

Make sure to wear safety glasses!



Low-gear

High-gear

